

# Structural Calculations Cover Sheet

**Project Number:** 2022.136  
**Project Name:** Li Residence

**Date:** October 13, 2022  
**Architect:** Shawn Sullivan

**Structural Design For:** Structural design for a new residence built using some elements of an existing foundation.

**Construction Type:** Conventional wood framing with conventional concrete foundation. Some steel elements as needed.

## CODES

2018 International Building Code (IBC)  
2018 NDS  
ASCE 7-16

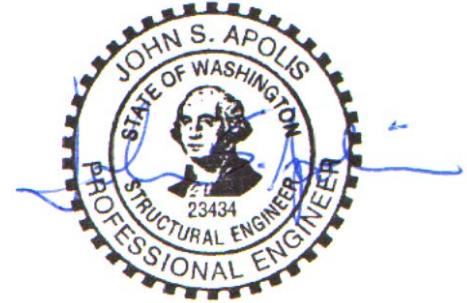

## LOADS

Dead Loads As required  
Roof snow Load 25 psf  
Floor Load 40 psf, 60 psf (decks)  
Wind 110 mph, Exposure B, Per ASCE 7-16 Section 28,  $K_{zt} = 1.60$   
Seismic Per ASCE 7-16 Section 12  
Peak Ground Accelerations (PGA) based on USGS Hazards Program (by address).  
PGA 1 sec = .499    PGA .2 sec = 1.436    %V = .147 \* DL

## Material Design Values

Soils (assumed) Minimum 1,500 psf allowed bearing (subject to field verification)  
Concrete  $f_c = 2,500$  psi; 5-1/2 sack mix, or alternate mix pre-approved by bldg. dept.  
Reinforcing Grade 60;  $F_y = 60,000$  psi minimum  
Sawn Lumber Joists, Rafters: HF #2 and better  
Beams: 4x\_: DF-L #2  
6x\_: DF-L #2  
Posts: DF-L #2  
Studs & Plates: Hem-Fir Standard  
Glu-Lam Beams 24F-V4 for simple span beams, 24F-V8 for cantilevered beams  
Parallam Beams 2.2E PSL,  $F_b = 2,900$  psi,  $F_v = 290$  psi,  $E = 2.0 \times 10^6$  psi (minimum)  
Microllam Beams 1.9E LVL,  $F_b = 2,600$  psi,  $F_v = 285$  psi,  $E = 1.9 \times 10^6$  psi (minimum)  
Timberstrand Bms 1.7E LSL,  $F_b = 2,600$  psi,  $F_v = 400$  psi,  $E = 1.7 \times 10^6$  psi (minimum)  
Structural Steel ASTM A36,  $F_y = 36$  ksi Plates, ASTM A500,  $F_y = 46$  ksi Tubes  
Anchor Bolts ASTM A325 hold down bolts, F1554 Anchor Bolts, A307 other bolts

Roof, R1: North Roof Joist  
1 piece(s) 11 7/8" TJI @ 210 @ 24" OC

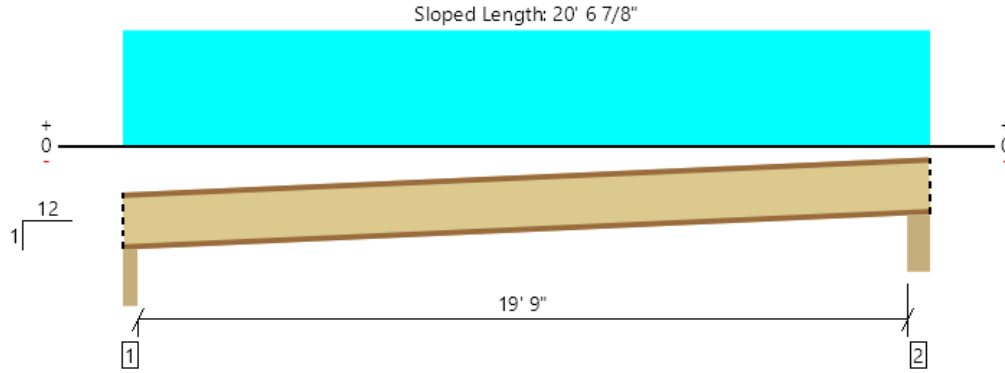

All locations are measured from the outside face of left support (or left cantilever end). All dimensions are horizontal.

Member Length : 20' 7 13/16"

Design Results	Actual @ Location	Allowed	Result	LDF	Load: Combination (Pattern)
Member Reaction (lbs)	828 @ 20' 1 1/2"	1679 (3.50")	Passed (49%)	1.15	1.0 D + 1.0 S (All Spans)
Shear (lbs)	791 @ 3 1/2"	1903	Passed (42%)	1.15	1.0 D + 1.0 S (All Spans)
Moment (Ft-lbs)	3972 @ 10' 2"	4364	Passed (91%)	1.15	1.0 D + 1.0 S (All Spans)
Live Load Defl. (in)	0.610 @ 10' 2"	0.999	Passed (L/393)	--	1.0 D + 1.0 S (All Spans)
Total Load Defl. (in)	0.978 @ 10' 2"	1.332	Passed (L/245)	--	1.0 D + 1.0 S (All Spans)

System : Roof  
Member Type : Joist  
Building Use : Residential  
Building Code : IBC 2018  
Design Methodology : ASD  
Member Pitch : 1/12

- Deflection criteria: LL (L/240) and TL (L/180).
- Allowed moment does not reflect the adjustment for the beam stability factor.

Supports	Bearing Length			Loads to Supports (lbs)			Accessories
	Total	Available	Required	Dead	Snow	Factored	
1 - Beveled Plate - SPF	3.50"	3.50"	1.75"	306	508	814	Blocking
2 - Beveled Plate - SPF	5.50"	5.50"	1.75"	311	517	828	Blocking

- Blocking Panels are assumed to carry no loads applied directly above them and the full load is applied to the member being designed.

Lateral Bracing	Bracing Intervals	Comments
Top Edge (Lu)	3' 6" o/c	
Bottom Edge (Lu)	20' 7" o/c	

- TJI joists are only analyzed using Maximum Allowable bracing solutions.
- Maximum allowable bracing intervals based on applied load.

Vertical Load	Location	Spacing	Dead (0.90)	Snow (1.15)	Comments
1 - Uniform (PSF)	0 to 20' 6"	24"	15.0	25.0	Default Load

**Weyerhaeuser Notes**

Weyerhaeuser warrants that the sizing of its products will be in accordance with Weyerhaeuser product design criteria and published design values. Weyerhaeuser expressly disclaims any other warranties related to the software. Use of this software is not intended to circumvent the need for a design professional as determined by the authority having jurisdiction. The designer of record, builder or framer is responsible to assure that this calculation is compatible with the overall project. Accessories (Rim Board, Blocking Panels and Squash Blocks) are not designed by this software. Products manufactured at Weyerhaeuser facilities are third-party certified to sustainable forestry standards. Weyerhaeuser Engineered Lumber Products have been evaluated by ICC-ES under evaluation reports ESR-1153 and ESR-1387 and/or tested in accordance with applicable ASTM standards. For current code evaluation reports, Weyerhaeuser product literature and installation details refer to [www.weyerhaeuser.com/woodproducts/document-library](http://www.weyerhaeuser.com/woodproducts/document-library).

The product application, input design loads, dimensions and support information have been provided by ForteWEB Software Operator

ForteWEB Software Operator	Job Notes
William Nocka CSES (978) 503-9935 11wnocka@gmail.com	



Roof, R2: North East Rim  
 1 piece(s) 1 3/4" x 11 7/8" 2.0E Microllam® LVL

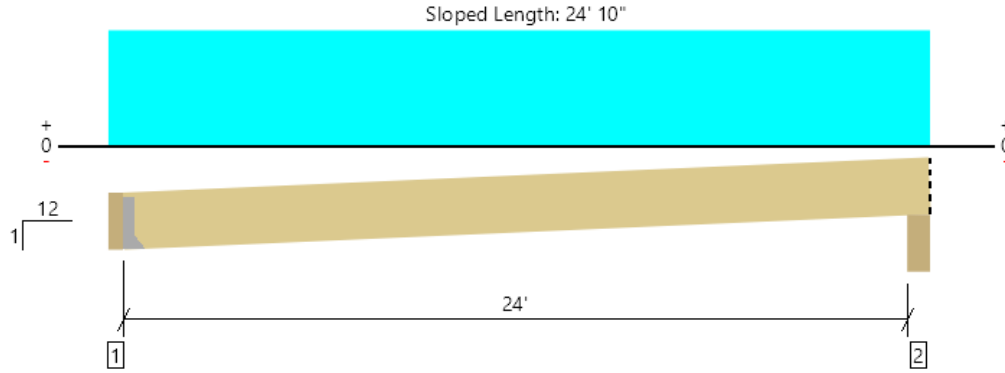

All locations are measured from the outside face of left support (or left cantilever end). All dimensions are horizontal.

Member Length : 24' 7 1/2"

Design Results	Actual @ Location	Allowed	Result	LDF	Load: Combination (Pattern)
Member Reaction (lbs)	556 @ 3 1/2"	1969 (1.50")	Passed (28%)	--	1.0 D + 1.0 S (All Spans)
Shear (lbs)	511 @ 1' 3 5/16"	4541	Passed (11%)	1.15	1.0 D + 1.0 S (All Spans)
Moment (Ft-lbs)	3356 @ 12' 4 1/4"	10263	Passed (33%)	1.15	1.0 D + 1.0 S (All Spans)
Live Load Defl. (in)	0.403 @ 12' 4 1/4"	1.210	Passed (L/721)	--	1.0 D + 1.0 S (All Spans)
Total Load Defl. (in)	0.744 @ 12' 4 1/4"	1.614	Passed (L/391)	--	1.0 D + 1.0 S (All Spans)

System : Roof  
 Member Type : Flush Beam  
 Building Use : Residential  
 Building Code : IBC 2018  
 Design Methodology : ASD  
 Member Pitch : 1/12

- Deflection criteria: LL (L/240) and TL (L/180).
- Allowed moment does not reflect the adjustment for the beam stability factor.

Supports	Bearing Length			Loads to Supports (lbs)			Accessories
	Total	Available	Required	Dead	Snow	Factored	
1 - Hanger on 11 7/8" SPF beam	3.50"	Hanger <sup>1</sup>	1.50"	259	309	568	See note <sup>1</sup>
2 - Beveled Plate - SPF	5.50"	5.50"	1.50"	262	310	572	Blocking

- Blocking Panels are assumed to carry no loads applied directly above them and the full load is applied to the member being designed.
- At hanger supports, the Total Bearing dimension is equal to the width of the material that is supporting the hanger
- <sup>1</sup> See Connector grid below for additional information and/or requirements.

Lateral Bracing	Bracing Intervals	Comments
Top Edge (Lu)	14' 2" o/c	
Bottom Edge (Lu)	24' 7" o/c	

•Maximum allowable bracing intervals based on applied load.

Connector: Simpson Strong-Tie						
Support	Model	Seat Length	Top Fasteners	Face Fasteners	Member Fasteners	Accessories
1 - Face Mount Hanger	LSSR1.81Z	1.88"	N/A	14-10dx2.5	12-10dx1.5	

- Refer to manufacturer notes and instructions for proper installation and use of all connectors.

Vertical Loads	Location (Side)	Tributary Width	Dead (0.90)	Snow (1.15)	Comments
0 - Self Weight (PLF)	3 1/2" to 24' 9"	N/A	6.1	--	
1 - Uniform (PSF)	0 to 24' 9"	1'	15.0	25.0	Default Load

**Weyerhaeuser Notes**  
 Weyerhaeuser warrants that the sizing of its products will be in accordance with Weyerhaeuser product design criteria and published design values. Weyerhaeuser expressly disclaims any other warranties related to the software. Use of this software is not intended to circumvent the need for a design professional as determined by the authority having jurisdiction. The designer of record, builder or framer is responsible to assure that this calculation is compatible with the overall project. Accessories (Rim Board, Blocking Panels and Squash Blocks) are not designed by this software. Products manufactured at Weyerhaeuser facilities are third-party certified to sustainable forestry standards. Weyerhaeuser Engineered Lumber Products have been evaluated by ICC-ES under evaluation reports ESR-1153 and ESR-1387 and/or tested in accordance with applicable ASTM standards. For current code evaluation reports, Weyerhaeuser product literature and installation details refer to [www.weyerhaeuser.com/woodproducts/document-library](http://www.weyerhaeuser.com/woodproducts/document-library).  
 The product application, input design loads, dimensions and support information have been provided by ForteWEB Software Operator

ForteWEB Software Operator	Job Notes
William Nocka CSES (978) 503-9935 11wnocka@gmail.com	



Roof, R3: East Rim Cantilever  
 1 piece(s) 1 3/4" x 11 7/8" 2.0E Microllam® LVL

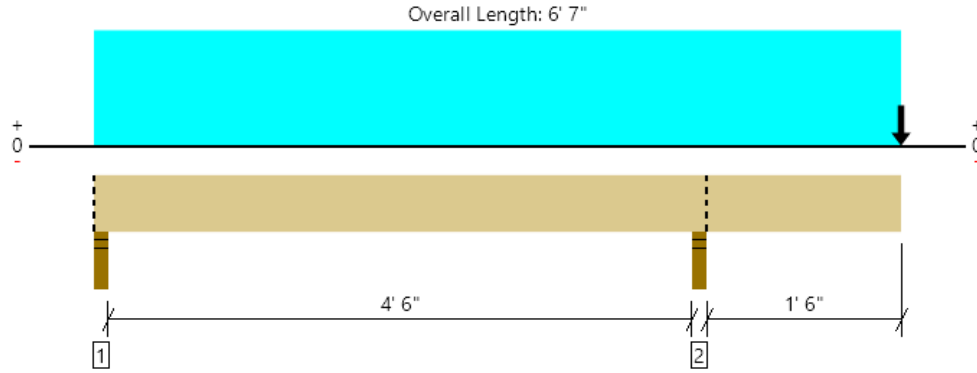

All locations are measured from the outside face of left support (or left cantilever end). All dimensions are horizontal.

Design Results	Actual @ Location	Allowed	Result	LDF	Load: Combination (Pattern)
Member Reaction (lbs)	2344 @ 4' 11 1/4"	2603 (3.50")	Passed (90%)	--	1.0 D + 1.0 S (All Spans)
Shear (lbs)	757 @ 3' 9 5/8"	4541	Passed (17%)	1.15	1.0 D + 1.0 S (All Spans)
Moment (Ft-lbs)	-1431 @ 4' 11 1/4"	10263	Passed (14%)	1.15	1.0 D + 1.0 S (All Spans)
Live Load Defl. (in)	0.011 @ 6' 7"	0.200	Passed (2L/999+)	--	1.0 D + 1.0 S (Alt Spans)
Total Load Defl. (in)	0.019 @ 6' 7"	0.219	Passed (2L/999+)	--	1.0 D + 1.0 S (Alt Spans)

System : Roof  
 Member Type : Flush Beam  
 Building Use : Residential  
 Building Code : IBC 2018  
 Design Methodology : ASD  
 Member Pitch : 0/12

- Deflection criteria: LL (L/240) and TL (L/180).
- Overhang deflection criteria: LL (0.2") and TL (2L/180).
- Allowed moment does not reflect the adjustment for the beam stability factor.

Supports	Bearing Length			Loads to Supports (lbs)			Accessories
	Total	Available	Required	Dead	Snow	Factored	
1 - Stud wall - SPF	3.50"	3.50"	1.50"	231	489	720	Blocking
2 - Stud wall - SPF	3.50"	3.50"	3.15"	957	1387	2344	Blocking

• Blocking Panels are assumed to carry no loads applied directly above them and the full load is applied to the member being designed.

Lateral Bracing	Bracing Intervals	Comments
Top Edge (Lu)	6' 7" o/c	
Bottom Edge (Lu)	6' 7" o/c	

•Maximum allowable bracing intervals based on applied load.

Vertical Loads	Location (Side)	Tributary Width	Dead (0.90)	Snow (1.15)	Comments
0 - Self Weight (PLF)	0 to 6' 7"	N/A	6.1	--	
1 - Uniform (PSF)	0 to 6' 7" (Front)	9'	15.0	25.0	Default Load
2 - Point (lb)	6' 7" (Front)	N/A	259	309	

**Weyerhaeuser Notes**

Weyerhaeuser warrants that the sizing of its products will be in accordance with Weyerhaeuser product design criteria and published design values. Weyerhaeuser expressly disclaims any other warranties related to the software. Use of this software is not intended to circumvent the need for a design professional as determined by the authority having jurisdiction. The designer of record, builder or framer is responsible to assure that this calculation is compatible with the overall project. Accessories (Rim Board, Blocking Panels and Squash Blocks) are not designed by this software. Products manufactured at Weyerhaeuser facilities are third-party certified to sustainable forestry standards. Weyerhaeuser Engineered Lumber Products have been evaluated by ICC-ES under evaluation reports ESR-1153 and ESR-1387 and/or tested in accordance with applicable ASTM standards. For current code evaluation reports, Weyerhaeuser product literature and installation details refer to [www.weyerhaeuser.com/woodproducts/document-library](http://www.weyerhaeuser.com/woodproducts/document-library).

The product application, input design loads, dimensions and support information have been provided by ForteWEB Software Operator

ForteWEB Software Operator	Job Notes
William Nocka CSES (978) 503-9935 11wnocka@gmail.com	



Roof, R4: South Roof Eave Joist  
1 piece(s) 11 7/8" TJI @ 210 @ 24" OC

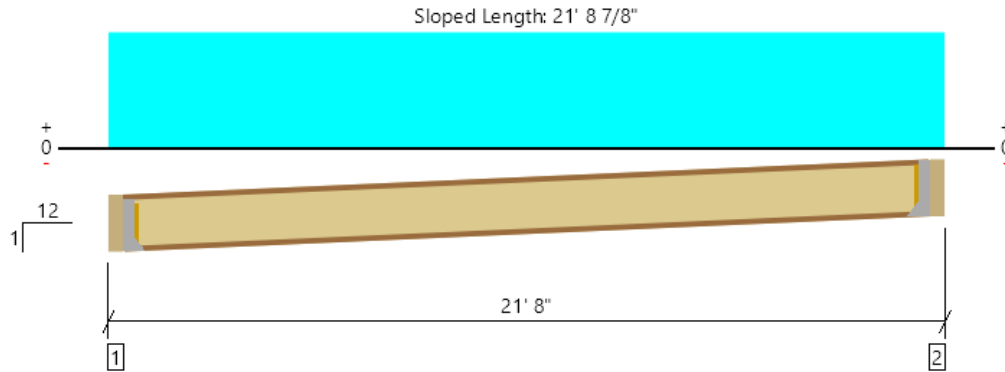

All locations are measured from the outside face of left support (or left cantilever end). All dimensions are horizontal.

Member Length : 21' 2 7/8"

Design Results	Actual @ Location	Allowed	Result	LDF	Load: Combination (Pattern)
Member Reaction (lbs)	844 @ 3 1/2"	1156 (1.75")	Passed (73%)	1.15	1.0 D + 1.0 S (All Spans)
Shear (lbs)	844 @ 3 1/2"	1903	Passed (44%)	1.15	1.0 D + 1.0 S (All Spans)
Moment (Ft-lbs)	4451 @ 10' 10"	4364	Passed (102%)	1.15	1.0 D + 1.0 S (All Spans)
Live Load Defl. (in)	0.760 @ 10' 10"	1.058	Passed (L/334)	--	1.0 D + 1.0 S (All Spans)
Total Load Defl. (in)	1.218 @ 10' 10"	1.410	Passed (L/208)	--	1.0 D + 1.0 S (All Spans)

System : Roof  
Member Type : Joist  
Building Use : Residential  
Building Code : IBC 2018  
Design Methodology : ASD  
Member Pitch : 1/12

- Deflection criteria: LL (L/240) and TL (L/180).
- Allowed moment does not reflect the adjustment for the beam stability factor.

Supports	Bearing Length			Loads to Supports (lbs)			Accessories
	Total	Available	Required	Dead	Snow	Factored	
1 - Hanger on 11 7/8" SPF beam	3.50"	Hanger <sup>1</sup>	1.75" / - <sup>2</sup>	326	542	868	See note <sup>1</sup>
2 - Hanger on 11 7/8" SPF beam	3.50"	Hanger <sup>1</sup>	1.75" / - <sup>2</sup>	326	542	868	See note <sup>1</sup>

- At hanger supports, the Total Bearing dimension is equal to the width of the material that is supporting the hanger
- <sup>1</sup> See Connector grid below for additional information and/or requirements.
- <sup>2</sup> Required Bearing Length / Required Bearing Length with Web Stiffeners

Lateral Bracing	Bracing Intervals	Comments
Top Edge (Lu)	3' 3" o/c	
Bottom Edge (Lu)	21' 2" o/c	

- TJI joists are only analyzed using Maximum Allowable bracing solutions.
- Maximum allowable bracing intervals based on applied load.

Connector: Simpson Strong-Tie							
Support	Model	Seat Length	Top Fasteners	Face Fasteners	Member Fasteners	Accessories	
1 - Face Mount Hanger	LSSR2.1Z	1.88"	N/A	14-10dx2.5	12-10dx1.5	Web Stiffeners	
2 - Face Mount Hanger	LSSR2.1Z	1.88"	N/A	14-10dx2.5	12-10dx1.5	Web Stiffeners	

- Refer to manufacturer notes and instructions for proper installation and use of all connectors.

Vertical Load	Location	Spacing	Dead (0.90)	Snow (1.15)	Comments
1 - Uniform (PSF)	0 to 21' 8"	24"	15.0	25.0	Default Load

**Weyerhaeuser Notes**  
Weyerhaeuser warrants that the sizing of its products will be in accordance with Weyerhaeuser product design criteria and published design values. Weyerhaeuser expressly disclaims any other warranties related to the software. Use of this software is not intended to circumvent the need for a design professional as determined by the authority having jurisdiction. The designer of record, builder or framer is responsible to assure that this calculation is compatible with the overall project. Accessories (Rim Board, Blocking Panels and Squash Blocks) are not designed by this software. Products manufactured at Weyerhaeuser facilities are third-party certified to sustainable forestry standards. Weyerhaeuser Engineered Lumber Products have been evaluated by ICC-ES under evaluation reports ESR-1153 and ESR-1387 and/or tested in accordance with applicable ASTM standards. For current code evaluation reports, Weyerhaeuser product literature and installation details refer to [www.weyerhaeuser.com/woodproducts/document-library](http://www.weyerhaeuser.com/woodproducts/document-library).  
The product application, input design loads, dimensions and support information have been provided by ForteWEB Software Operator

ForteWEB Software Operator	Job Notes
William Nocka CSES (978) 503-9935 11wnocka@gmail.com	



Roof, R5: East Cantilever Flush Beam @ Valley  
 1 piece(s) 1 3/4" x 11 7/8" 2.0E Microllam® LVL

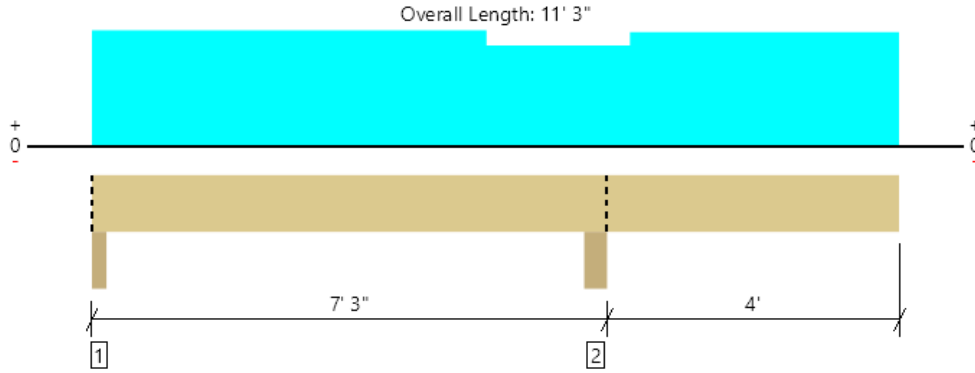

All locations are measured from the outside face of left support (or left cantilever end). All dimensions are horizontal.

Design Results	Actual @ Location	Allowed	Result	LDF	Load: Combination (Pattern)
Member Reaction (lbs)	6021 @ 7' 1/4"	7219 (5.50")	Passed (83%)	--	1.0 D + 1.0 S (All Spans)
Shear (lbs)	2419 @ 5' 9 5/8"	4541	Passed (53%)	1.15	1.0 D + 1.0 S (All Spans)
Moment (Ft-lbs)	-6126 @ 7' 1/4"	10263	Passed (60%)	1.15	1.0 D + 1.0 S (All Spans)
Live Load Defl. (in)	0.168 @ 11' 3"	0.423	Passed (2L/602)	--	1.0 D + 1.0 S (Alt Spans)
Total Load Defl. (in)	0.246 @ 11' 3"	0.564	Passed (2L/412)	--	1.0 D + 1.0 S (Alt Spans)

System : Roof  
 Member Type : Flush Beam  
 Building Use : Residential  
 Building Code : IBC 2018  
 Design Methodology : ASD  
 Member Pitch : 0/12

- Deflection criteria: LL (L/240) and TL (L/180).
- Overhang deflection criteria: LL (2L/240) and TL (2L/180).
- Right cantilever length exceeds 1/3 member length or 1/2 back span length. Additional bracing should be considered.
- Allowed moment does not reflect the adjustment for the beam stability factor.

Supports	Bearing Length			Loads to Supports (lbs)			Accessories
	Total	Available	Required	Dead	Snow	Factored	
1 - Column - DF	3.50"	3.50"	1.50"	606	1263	1869	Blocking
2 - Column - DF	5.50"	5.50"	4.59"	2292	3729	6021	Blocking

• Blocking Panels are assumed to carry no loads applied directly above them and the full load is applied to the member being designed.

Lateral Bracing	Bracing Intervals	Comments
Top Edge (Lu)	11' 3" o/c	
Bottom Edge (Lu)	6' 8" o/c	

•Maximum allowable bracing intervals based on applied load.

Vertical Loads	Location (Side)	Tributary Width	Dead (0.90)	Snow (1.15)	Comments
0 - Self Weight (PLF)	0 to 11' 3"	N/A	6.1	--	
1 - Uniform (PSF)	0 to 5' 6" (Front)	17' 3"	15.0	25.0	Default Load
2 - Uniform (PSF)	5' 6" to 7' 6" (Front)	15'	15.0	25.0	Default Load
3 - Uniform (PSF)	7' 6" to 11' 3" (Front)	17'	15.0	25.0	Default Load

**Weyerhaeuser Notes**

Weyerhaeuser warrants that the sizing of its products will be in accordance with Weyerhaeuser product design criteria and published design values. Weyerhaeuser expressly disclaims any other warranties related to the software. Use of this software is not intended to circumvent the need for a design professional as determined by the authority having jurisdiction. The designer of record, builder or framer is responsible to assure that this calculation is compatible with the overall project. Accessories (Rim Board, Blocking Panels and Squash Blocks) are not designed by this software. Products manufactured at Weyerhaeuser facilities are third-party certified to sustainable forestry standards. Weyerhaeuser Engineered Lumber Products have been evaluated by ICC-ES under evaluation reports ESR-1153 and ESR-1387 and/or tested in accordance with applicable ASTM standards. For current code evaluation reports, Weyerhaeuser product literature and installation details refer to [www.weyerhaeuser.com/woodproducts/document-library](http://www.weyerhaeuser.com/woodproducts/document-library).

The product application, input design loads, dimensions and support information have been provided by ForteWEB Software Operator

ForteWEB Software Operator	Job Notes
William Nocka CSES (978) 503-9935 11wnocka@gmail.com	



Roof, R6: South East Cantilever Flush Beam @ Rim  
 1 piece(s) 1 3/4" x 11 7/8" 2.0E MicroIam® LVL

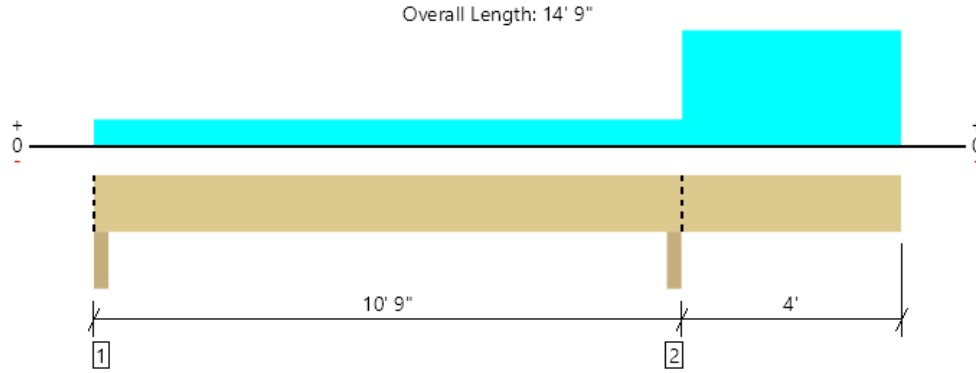

All locations are measured from the outside face of left support (or left cantilever end). All dimensions are horizontal.

Design Results	Actual @ Location	Allowed	Result	LDF	Load: Combination (Pattern)
Member Reaction (lbs)	2720 @ 10' 7 1/4"	4594 (3.50")	Passed (59%)	--	1.0 D + 1.0 S (All Spans)
Shear (lbs)	1343 @ 11' 8 7/8"	4541	Passed (30%)	1.15	1.0 D + 1.0 S (All Spans)
Moment (Ft-lbs)	-3830 @ 10' 7 1/4"	10263	Passed (37%)	1.15	1.0 D + 1.0 S (All Spans)
Live Load Defl. (in)	0.148 @ 14' 9"	0.415	Passed (2L/674)	--	1.0 D + 1.0 S (Alt Spans)
Total Load Defl. (in)	0.223 @ 14' 9"	0.553	Passed (2L/446)	--	1.0 D + 1.0 S (Alt Spans)

System : Roof  
 Member Type : Flush Beam  
 Building Use : Residential  
 Building Code : IBC 2018  
 Design Methodology : ASD  
 Member Pitch : 0/12

- Deflection criteria: LL (L/240) and TL (L/180).
- Overhang deflection criteria: LL (2L/240) and TL (2L/180).
- Allowed moment does not reflect the adjustment for the beam stability factor.

Supports	Bearing Length			Loads to Supports (lbs)			Accessories
	Total	Available	Required	Dead	Snow	Factored	
1 - Column - DF	3.50"	3.50"	1.50"	94	223/-58	317	Blocking
2 - Column - DF	3.50"	3.50"	2.07"	1059	1661	2720	Blocking

• Blocking Panels are assumed to carry no loads applied directly above them and the full load is applied to the member being designed.

Lateral Bracing	Bracing Intervals	Comments
Top Edge (Lu)	14' 9" o/c	
Bottom Edge (Lu)	12' 2" o/c	

•Maximum allowable bracing intervals based on applied load.

Vertical Loads	Location (Side)	Tributary Width	Dead (0.90)	Snow (1.15)	Comments
0 - Self Weight (PLF)	0 to 14' 9"	N/A	6.1	--	
1 - Uniform (PSF)	0 to 10' 9" (Front)	2' 6"	15.0	25.0	Default Load
2 - Uniform (PSF)	10' 9" to 14' 9" (Front)	11'	15.0	25.0	Default Load

**Weyerhaeuser Notes**

Weyerhaeuser warrants that the sizing of its products will be in accordance with Weyerhaeuser product design criteria and published design values. Weyerhaeuser expressly disclaims any other warranties related to the software. Use of this software is not intended to circumvent the need for a design professional as determined by the authority having jurisdiction. The designer of record, builder or framer is responsible to assure that this calculation is compatible with the overall project. Accessories (Rim Board, Blocking Panels and Squash Blocks) are not designed by this software. Products manufactured at Weyerhaeuser facilities are third-party certified to sustainable forestry standards. Weyerhaeuser Engineered Lumber Products have been evaluated by ICC-ES under evaluation reports ESR-1153 and ESR-1387 and/or tested in accordance with applicable ASTM standards. For current code evaluation reports, Weyerhaeuser product literature and installation details refer to [www.weyerhaeuser.com/woodproducts/document-library](http://www.weyerhaeuser.com/woodproducts/document-library).

The product application, input design loads, dimensions and support information have been provided by ForteWEB Software Operator

ForteWEB Software Operator	Job Notes
William Nocka CSES (978) 503-9935 11wnocka@gmail.com	



Roof, R7: South East Flush Beam @ Rim Cantilever Support  
 1 piece(s) 5 1/4" x 11 7/8" 2.2E Parallam® PSL

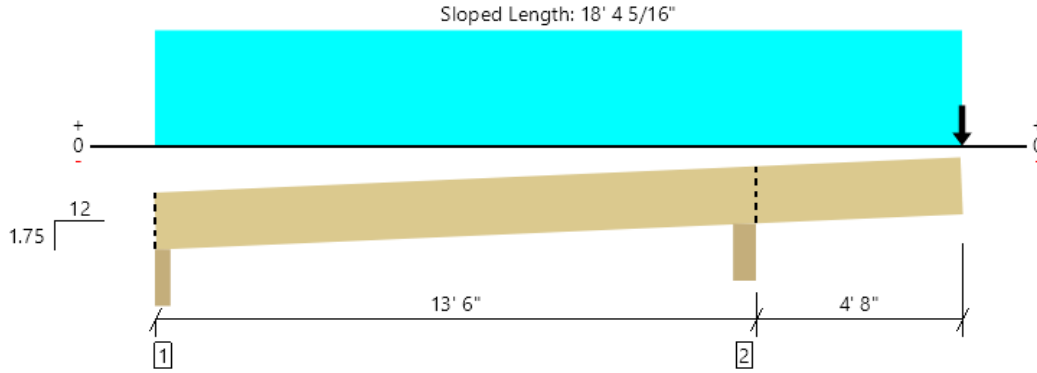

All locations are measured from the outside face of left support (or left cantilever end). All dimensions are horizontal.

Member Length : 18' 6 1/16"

Design Results	Actual @ Location	Allowed	Result	LDF	Load: Combination (Pattern)
Member Reaction (lbs)	4973 @ 13' 3 1/4"	12402 (5.50")	Passed (40%)	--	1.0 D + 1.0 S (All Spans)
Shear (lbs)	3089 @ 14' 5 3/4"	13861	Passed (22%)	1.15	1.0 D + 1.0 S (All Spans)
Moment (Ft-lbs)	-14515 @ 13' 3 1/4"	34332	Passed (42%)	1.15	1.0 D + 1.0 S (All Spans)
Live Load Defl. (in)	0.281 @ 18' 2"	0.495	Passed (2L/422)	--	1.0 D + 1.0 S (Alt Spans)
Total Load Defl. (in)	0.451 @ 18' 2"	0.660	Passed (2L/264)	--	1.0 D + 1.0 S (Alt Spans)

System : Roof  
 Member Type : Flush Beam  
 Building Use : Residential  
 Building Code : IBC 2018  
 Design Methodology : ASD  
 Member Pitch : 1.75/12

- Deflection criteria: LL (L/240) and TL (L/180).
- Overhang deflection criteria: LL (2L/240) and TL (2L/180).
- Allowed moment does not reflect the adjustment for the beam stability factor.
- -605 lbs uplift at support located at 2 1/4". Strapping or other restraint may be required.

Supports	Bearing Length			Loads to Supports (lbs)			Accessories
	Total	Available	Required	Dead	Snow	Factored	
1 - Beveled Plate - SPF	3.75"	3.75"	1.50"	-106	3/-499	-605	Blocking
2 - Beveled Plate - SPF	5.50"	5.50"	2.21"	2073	2900	4973	Blocking

- Blocking Panels are assumed to carry no loads applied directly above them and the full load is applied to the member being designed.

Lateral Bracing	Bracing Intervals	Comments
Top Edge (Lu)	18' 4" o/c	
Bottom Edge (Lu)	18' 4" o/c	

- Maximum allowable bracing intervals based on applied load.

Vertical Loads	Location (Side)	Tributary Width	Dead (0.90)	Snow (1.15)	Comments
0 - Self Weight (PLF)	0 to 18' 2"	N/A	19.5	--	
1 - Uniform (PSF)	0 to 18' 2"	2'	15.0	25.0	Default Load
2 - Point (lb)	18' 2"	N/A	1059	1661	

**Weyerhaeuser Notes**

Weyerhaeuser warrants that the sizing of its products will be in accordance with Weyerhaeuser product design criteria and published design values. Weyerhaeuser expressly disclaims any other warranties related to the software. Use of this software is not intended to circumvent the need for a design professional as determined by the authority having jurisdiction. The designer of record, builder or framer is responsible to assure that this calculation is compatible with the overall project. Accessories (Rim Board, Blocking Panels and Squash Blocks) are not designed by this software. Products manufactured at Weyerhaeuser facilities are third-party certified to sustainable forestry standards. Weyerhaeuser Engineered Lumber Products have been evaluated by ICC-ES under evaluation reports ESR-1153 and ESR-1387 and/or tested in accordance with applicable ASTM standards. For current code evaluation reports, Weyerhaeuser product literature and installation details refer to [www.weyerhaeuser.com/woodproducts/document-library](http://www.weyerhaeuser.com/woodproducts/document-library).

The product application, input design loads, dimensions and support information have been provided by ForteWEB Software Operator

ForteWEB Software Operator	Job Notes
William Nocka CSES (978) 503-9935 11wnocka@gmail.com	





Roof, R8: South East Flush Beam @ Rim Backspan Support  
 1 piece(s) 1 3/4" x 11 7/8" 2.0E Microllam® LVL

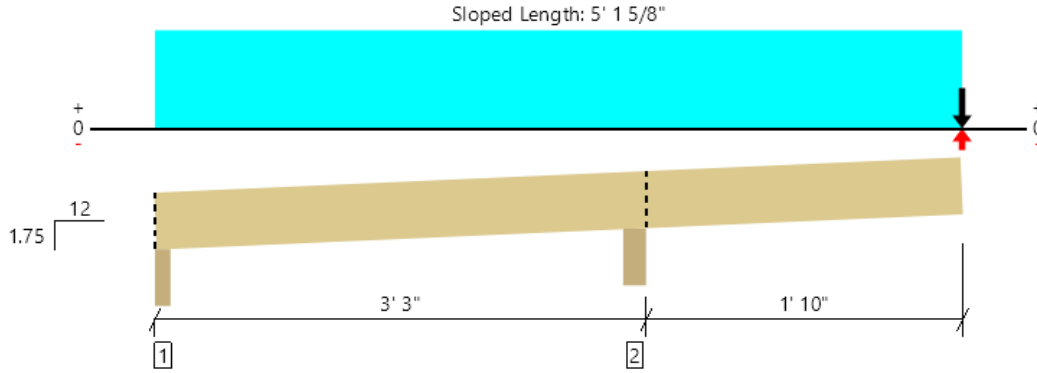

All locations are measured from the outside face of left support (or left cantilever end). All dimensions are horizontal.

Member Length : 5' 3 3/8"

Design Results	Actual @ Location	Allowed	Result	LDF	Load: Combination (Pattern)
Member Reaction (lbs)	813 @ 3' 1/4"	4134 (5.50")	Passed (20%)	--	1.0 D + 1.0 S (All Spans)
Shear (lbs)	333 @ 4' 2 3/4"	4541	Passed (7%)	1.15	1.0 D + 1.0 S (All Spans)
Moment (Ft-lbs)	-718 @ 3' 1/4"	10263	Passed (7%)	1.15	1.0 D + 1.0 S (All Spans)
Live Load Defl. (in)	0.008 @ 5' 1"	0.208	Passed (2L/999+)	--	1.0 D + 1.0 S (Alt Spans)
Total Load Defl. (in)	0.012 @ 5' 1"	0.278	Passed (2L/999+)	--	1.0 D + 1.0 S (Alt Spans)

System : Roof  
 Member Type : Flush Beam  
 Building Use : Residential  
 Building Code : IBC 2018  
 Design Methodology : ASD  
 Member Pitch : 1.75/12

- Deflection criteria: LL (L/240) and TL (L/180).
- Overhang deflection criteria: LL (2L/240) and TL (2L/180).
- Right cantilever length exceeds 1/3 member length or 1/2 back span length. Additional bracing should be considered.
- Allowed moment does not reflect the adjustment for the beam stability factor.

Supports	Bearing Length			Loads to Supports (lbs)			Accessories
	Total	Available	Required	Dead	Snow	Factored	
1 - Beveled Plate - SPF	3.75"	3.75"	1.50"	-37	1/-118	-155	Blocking
2 - Beveled Plate - SPF	5.50"	5.50"	1.50"	317	497	813	Blocking

• Blocking Panels are assumed to carry no loads applied directly above them and the full load is applied to the member being designed.

Lateral Bracing	Bracing Intervals	Comments
Top Edge (Lu)	5' 2" o/c	
Bottom Edge (Lu)	5' 2" o/c	

•Maximum allowable bracing intervals based on applied load.

Vertical Loads	Location (Side)	Tributary Width	Dead (0.90)	Snow (1.15)	Comments
0 - Self Weight (PLF)	0 to 5' 1"	N/A	6.1	--	
1 - Uniform (PSF)	0 to 5' 1"	2'	15.0	25.0	Default Load
2 - Point (lb)	5' 1"	N/A	94	223	
3 - Point (lb)	5' 1"	N/A	-	-58	

**Weyerhaeuser Notes**

Weyerhaeuser warrants that the sizing of its products will be in accordance with Weyerhaeuser product design criteria and published design values. Weyerhaeuser expressly disclaims any other warranties related to the software. Use of this software is not intended to circumvent the need for a design professional as determined by the authority having jurisdiction. The designer of record, builder or framer is responsible to assure that this calculation is compatible with the overall project. Accessories (Rim Board, Blocking Panels and Squash Blocks) are not designed by this software. Products manufactured at Weyerhaeuser facilities are third-party certified to sustainable forestry standards. Weyerhaeuser Engineered Lumber Products have been evaluated by ICC-ES under evaluation reports ESR-1153 and ESR-1387 and/or tested in accordance with applicable ASTM standards. For current code evaluation reports, Weyerhaeuser product literature and installation details refer to [www.weyerhaeuser.com/woodproducts/document-library](http://www.weyerhaeuser.com/woodproducts/document-library).

The product application, input design loads, dimensions and support information have been provided by ForteWEB Software Operator

ForteWEB Software Operator	Job Notes
William Nocka CSES (978) 503-9935 11wnocka@gmail.com	



John S. Apolis, P.E.

CSES, Inc.

Job number: 2022.136

Project: Li Residence

Date: 13-Oct-22

Designer: Shawn Sullivan

Page number: R9

**Post Design (Combined Axial and Moment Loading)**

2018 International Building Code (IBC)

2018 NDS

**Post Description: Beam R7 South Support**

Snow Load:	1	Wind Load:	
Repetitive Member:		P.T. Lumber:	

**Geometry and loads:**

Height	11 ft	w(d)	0 plf	M(d)	
Axial Load	4973 lbs	w(b)	0 plf	M(b)	0 ft-lbs
Le(d)	11 ft	Le(b)	0.5 ft		

**Material Properties:**

Fb1	875 psi	Fb(d)'	1006.3 psi
Fb2	875 psi	Fb(b)'	1006.3 psi
Fc	1350 psi	Fc'	708.67 psi
E	1.6 msi	E'	1.6 msi
Emin	0.58 msi	Emin'	0.58 msi

**Selected Member: DF #2 5.5 x 5.5**

**Member properties:**

Section Modulus (d):	27.7 in^3
Section Modulus (b):	27.7 in^3
Section Area:	30.3 in^2

**Variables:**

Rb(d)	4.90
Rb(b)	1.04
c	0.8

**Member stresses: Provided**

FcE(d)	828 psi	>
FcE(b)	400611 psi	>
FbE	29000 psi	>
FbE	29000 psi	>

**Required**

fc	164 psi	OK
fc	164 psi	OK
fb(d)	0 psi	OK
fb(b)	0 psi	OK

**Bending and Axial Compression Check:**

NDS 2018 EQ 3.9-3 0.05 < 1.0 **OK**

Roof, R10: South West Flush Beam @ Rim  
 1 piece(s) 1 3/4" x 11 7/8" 2.0E Microllam® LVL

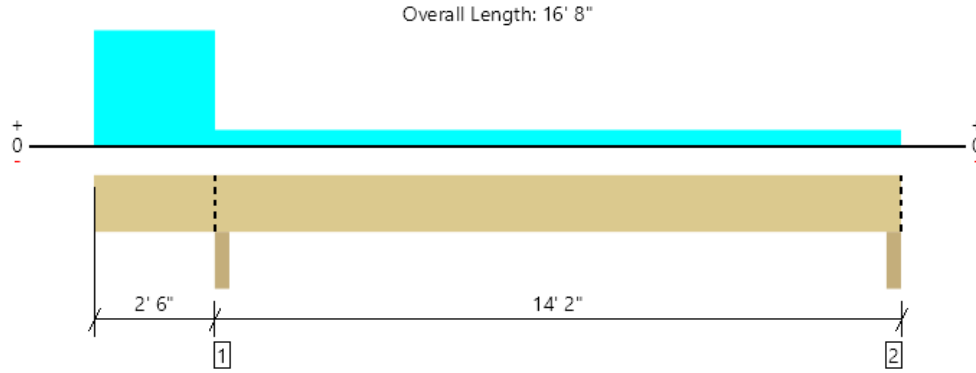

All locations are measured from the outside face of left support (or left cantilever end). All dimensions are horizontal.

Design Results	Actual @ Location	Allowed	Result	LDF	Load: Combination (Pattern)
Member Reaction (lbs)	1695 @ 2' 7 3/4"	2603 (3.50")	Passed (65%)	--	1.0 D + 1.0 S (All Spans)
Shear (lbs)	674 @ 1' 6 1/8"	4541	Passed (15%)	1.15	1.0 D + 1.0 S (All Spans)
Moment (Ft-lbs)	-1557 @ 2' 7 3/4"	10263	Passed (15%)	1.15	1.0 D + 1.0 S (All Spans)
Live Load Defl. (in)	0.033 @ 0	0.265	Passed (2L/999+)	--	1.0 D + 1.0 S (All Spans)
Total Load Defl. (in)	0.037 @ 0	0.353	Passed (2L/999+)	--	1.0 D + 1.0 S (All Spans)

System : Roof  
 Member Type : Flush Beam  
 Building Use : Residential  
 Building Code : IBC 2018  
 Design Methodology : ASD  
 Member Pitch : 0/12

- Deflection criteria: LL (L/240) and TL (L/180).
- Overhang deflection criteria: LL (2L/240) and TL (2L/180).
- Allowed moment does not reflect the adjustment for the beam stability factor.

Supports	Bearing Length			Loads to Supports (lbs)			Accessories
	Total	Available	Required	Dead	Snow	Factored	
1 - Beam - SPF	3.50"	3.50"	2.28"	673	1022	1695	Blocking
2 - Beam - SPF	3.50"	3.50"	1.50"	159	231	391	Blocking

- Blocking Panels are assumed to carry no loads applied directly above them and the full load is applied to the member being designed.

Lateral Bracing	Bracing Intervals	Comments
Top Edge (Lu)	16' 8" o/c	
Bottom Edge (Lu)	16' 8" o/c	

- Maximum allowable bracing intervals based on applied load.

Vertical Loads	Location (Side)	Tributary Width	Dead (0.90)	Snow (1.15)	Comments
0 - Self Weight (PLF)	0 to 16' 8"	N/A	6.1	--	
1 - Uniform (PSF)	2' 6" to 16' 8" (Front)	1' 6"	15.0	25.0	Default Load
2 - Uniform (PSF)	0 to 2' 6" (Front)	11'	15.0	25.0	Default Load

#### Weyerhaeuser Notes

Weyerhaeuser warrants that the sizing of its products will be in accordance with Weyerhaeuser product design criteria and published design values. Weyerhaeuser expressly disclaims any other warranties related to the software. Use of this software is not intended to circumvent the need for a design professional as determined by the authority having jurisdiction. The designer of record, builder or framer is responsible to assure that this calculation is compatible with the overall project. Accessories (Rim Board, Blocking Panels and Squash Blocks) are not designed by this software. Products manufactured at Weyerhaeuser facilities are third-party certified to sustainable forestry standards. Weyerhaeuser Engineered Lumber Products have been evaluated by ICC-ES under evaluation reports ESR-1153 and ESR-1387 and/or tested in accordance with applicable ASTM standards. For current code evaluation reports, Weyerhaeuser product literature and installation details refer to [www.weyerhaeuser.com/woodproducts/document-library](http://www.weyerhaeuser.com/woodproducts/document-library).

The product application, input design loads, dimensions and support information have been provided by ForteWEB Software Operator

ForteWEB Software Operator	Job Notes
William Nocka CSES (978) 503-9935 11wnocka@gmail.com	



Roof, R11: South West Flush Beam @ Rim Cantilever  
 1 piece(s) 3 1/2" x 11 7/8" 2.2E Parallam® PSL

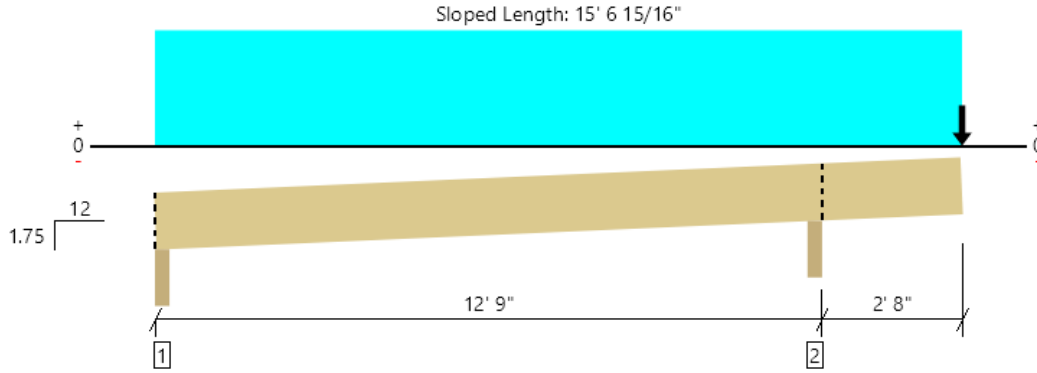

All locations are measured from the outside face of left support (or left cantilever end). All dimensions are horizontal.

Member Length : 15' 8 11/16"

Design Results	Actual @ Location	Allowed	Result	LDF	Load: Combination (Pattern)
Member Reaction (lbs)	2952 @ 12' 7 1/4"	5261 (3.50")	Passed (56%)	--	1.0 D + 1.0 S (All Spans)
Shear (lbs)	1853 @ 13' 8 3/4"	9241	Passed (20%)	1.15	1.0 D + 1.0 S (All Spans)
Moment (Ft-lbs)	-5137 @ 12' 7 1/4"	22888	Passed (22%)	1.15	1.0 D + 1.0 S (All Spans)
Live Load Defl. (in)	0.070 @ 15' 5"	0.284	Passed (2L/968)	--	1.0 D + 1.0 S (Alt Spans)
Total Load Defl. (in)	0.108 @ 15' 5"	0.379	Passed (2L/632)	--	1.0 D + 1.0 S (Alt Spans)

System : Roof  
 Member Type : Flush Beam  
 Building Use : Residential  
 Building Code : IBC 2018  
 Design Methodology : ASD  
 Member Pitch : 1.75/12

- Deflection criteria: LL (L/240) and TL (L/180).
- Overhang deflection criteria: LL (2L/240) and TL (2L/180).
- Allowed moment does not reflect the adjustment for the beam stability factor.

Supports	Bearing Length			Loads to Supports (lbs)			Accessories
	Total	Available	Required	Dead	Snow	Factored	
1 - Beveled Plate - SPF	3.50"	3.50"	1.50"	111	196/-87	307	Blocking
2 - Beveled Plate - SPF	3.50"	3.50"	1.96"	1231	1721	2952	Blocking

• Blocking Panels are assumed to carry no loads applied directly above them and the full load is applied to the member being designed.

Lateral Bracing	Bracing Intervals	Comments
Top Edge (Lu)	15' 7" o/c	
Bottom Edge (Lu)	15' 7" o/c	

•Maximum allowable bracing intervals based on applied load.

Vertical Loads	Location (Side)	Tributary Width	Dead (0.90)	Snow (1.15)	Comments
0 - Self Weight (PLF)	0 to 15' 5"	N/A	13.0	--	
1 - Uniform (PSF)	0 to 15' 5"	2'	15.0	25.0	Default Load
2 - Point (lb)	15' 5"	N/A	673	1022	

**Weyerhaeuser Notes**

Weyerhaeuser warrants that the sizing of its products will be in accordance with Weyerhaeuser product design criteria and published design values. Weyerhaeuser expressly disclaims any other warranties related to the software. Use of this software is not intended to circumvent the need for a design professional as determined by the authority having jurisdiction. The designer of record, builder or framer is responsible to assure that this calculation is compatible with the overall project. Accessories (Rim Board, Blocking Panels and Squash Blocks) are not designed by this software. Products manufactured at Weyerhaeuser facilities are third-party certified to sustainable forestry standards. Weyerhaeuser Engineered Lumber Products have been evaluated by ICC-ES under evaluation reports ESR-1153 and ESR-1387 and/or tested in accordance with applicable ASTM standards. For current code evaluation reports, Weyerhaeuser product literature and installation details refer to [www.weyerhaeuser.com/woodproducts/document-library](http://www.weyerhaeuser.com/woodproducts/document-library).

The product application, input design loads, dimensions and support information have been provided by ForteWEB Software Operator

ForteWEB Software Operator	Job Notes
William Nocka CSES (978) 503-9935 11wnocka@gmail.com	



Roof, R12: South West Flush Beam @ Rim Backspan  
 1 piece(s) 1 3/4" x 11 7/8" 2.0E MicroIam® LVL

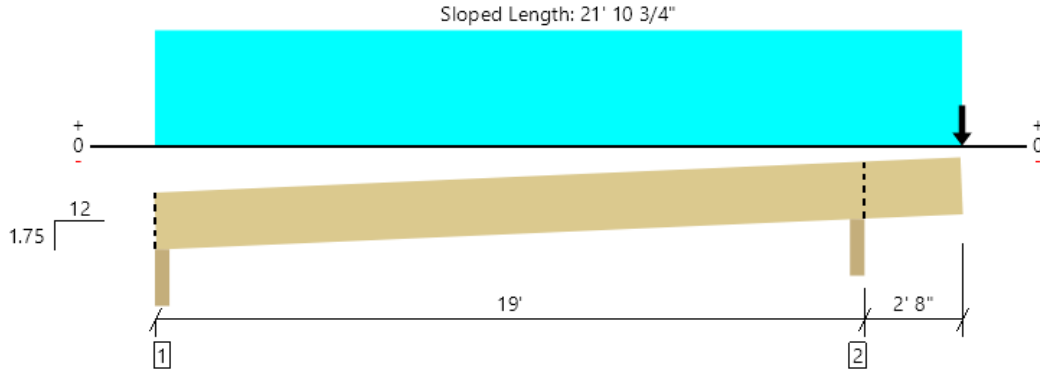

All locations are measured from the outside face of left support (or left cantilever end). All dimensions are horizontal.

Member Length : 22' 1/2"

Design Results	Actual @ Location	Allowed	Result	LDF	Load: Combination (Pattern)
Member Reaction (lbs)	1518 @ 18' 10 1/4"	2631 (3.50")	Passed (58%)	--	1.0 D + 1.0 S (All Spans)
Shear (lbs)	787 @ 17' 8 3/4"	4541	Passed (17%)	1.15	1.0 D + 1.0 S (All Spans)
Moment (Ft-lbs)	3283 @ 8' 10 9/16"	10263	Passed (32%)	1.15	1.0 D + 1.0 S (All Spans)
Live Load Defl. (in)	0.266 @ 9' 4 1/8"	0.944	Passed (L/853)	--	1.0 D + 1.0 S (All Spans)
Total Load Defl. (in)	0.437 @ 9' 3 1/4"	1.259	Passed (L/518)	--	1.0 D + 1.0 S (All Spans)

System : Roof  
 Member Type : Flush Beam  
 Building Use : Residential  
 Building Code : IBC 2018  
 Design Methodology : ASD  
 Member Pitch : 1.75/12

- Deflection criteria: LL (L/240) and TL (L/180).
- Overhang deflection criteria: LL (2L/240) and TL (2L/180).
- Allowed moment does not reflect the adjustment for the beam stability factor.

Supports	Bearing Length			Loads to Supports (lbs)			Accessories
	Total	Available	Required	Dead	Snow	Factored	
1 - Beveled Plate - SPF	3.50"	3.50"	1.50"	315	453	768	Blocking
2 - Beveled Plate - SPF	3.50"	3.50"	2.02"	634	884	1518	Blocking

• Blocking Panels are assumed to carry no loads applied directly above them and the full load is applied to the member being designed.

Lateral Bracing	Bracing Intervals	Comments
Top Edge (Lu)	14' 6" o/c	
Bottom Edge (Lu)	21' 11" o/c	

•Maximum allowable bracing intervals based on applied load.

Vertical Loads	Location (Side)	Tributary Width	Dead (0.90)	Snow (1.15)	Comments
0 - Self Weight (PLF)	0 to 21' 8"	N/A	6.1	--	
1 - Uniform (PSF)	0 to 21' 8"	2'	15.0	25.0	Default Load
2 - Point (lb)	21' 8"	N/A	159	231	

**Weyerhaeuser Notes**

Weyerhaeuser warrants that the sizing of its products will be in accordance with Weyerhaeuser product design criteria and published design values. Weyerhaeuser expressly disclaims any other warranties related to the software. Use of this software is not intended to circumvent the need for a design professional as determined by the authority having jurisdiction. The designer of record, builder or framer is responsible to assure that this calculation is compatible with the overall project. Accessories (Rim Board, Blocking Panels and Squash Blocks) are not designed by this software. Products manufactured at Weyerhaeuser facilities are third-party certified to sustainable forestry standards. Weyerhaeuser Engineered Lumber Products have been evaluated by ICC-ES under evaluation reports ESR-1153 and ESR-1387 and/or tested in accordance with applicable ASTM standards. For current code evaluation reports, Weyerhaeuser product literature and installation details refer to [www.weyerhaeuser.com/woodproducts/document-library](http://www.weyerhaeuser.com/woodproducts/document-library).

The product application, input design loads, dimensions and support information have been provided by ForteWEB Software Operator

ForteWEB Software Operator	Job Notes
William Nocka CSES (978) 503-9935 11wnocka@gmail.com	



John S. Apolis, P.E. CSES, Inc.

Job number: 2022.136

Project: Li Residence

Date: 13-Oct-22

Designer: Shawn Sullivan

Page number: R13

**BEAM DESIGN (Uniform Load+Concentrated Load)**

2018 International Building Code (IBC)

2018 NDS

**Beam Description: South West Window Header**

Fully Supported:	1	Snow Load:	1	Wind Load:	
Repetitive Member:		P.T. Lumber:		Wet Use:	

**Geometry and Loads:**

Span:	13.25 ft	Tributary Width:	10.5 ft	P Location:	3.75 ft
Add'l uniform DL:		DL unit load:	15 psf	Concentrated DL:	
Add'l uniform LL:		LL unit load:		Concentrated LL:	
Add'l uniform SL:		SL unit load:	25 psf	Concentrated SL:	
Add'l uniform WL:		WL unit load:		Concentrated WL:	

DL Reaction 1:	1043 lbs	DL Reaction 2:	1043 lbs	Note: Design automatically uses
LL Reaction 1:	0 lbs	LL Reaction 2:	0 lbs	ASD load combinations
SL Reaction 1:	1739 lbs	SL Reaction 2:	1739 lbs	
WL Reaction 1:	0 lbs	WL Reaction 2:	0 lbs	
Total Reaction 1:	<b>2783 lbs</b>	Total Reaction 2:	<b>2783 lbs</b>	

**Material Properties:**

E	2.2 msi	E'	2.2 msi
Fb	2900 psi	Fb'	3433 psi
Fv	290 psi	Fv'	334 psi
Fc perp	625 psi	Fc perp'	625 psi
Emin	0.914 msi	Emin'	0.914 msi

**Deflection analysis:**

For total load: Allowed deflection criteria, span/	240		
For LL only: Allowed deflection criteria, span/	360		
Max. allowed total defl:	0.66 in	Max LL defl:	0.44 in
Total defl. * I:	132.4 in^4	Required I:	199.84 in^4
LL defl. * I:	82.75 in^4	Required I:	187.35 in^4
Actual deflections:	TOTAL: 0.57 in		0.36 in

**Force analysis:**

Max. moment:	9217 ft-lb	Max Shear:	2783 lbs
--------------	------------	------------	----------

**Selected Member: (1) PSL 3.5 x 9.25**

<b>Member properties:</b>	<b>Provided:</b>	<b>Required:</b>
Moment of inertia:	230.84 in^4	199.84 in^4
Section Modulus:	49.91 in^3	32.22 in^3
Section Area:	32.38 in^2	12.51 in^2
Bearing Area:		4.45 in^2
Minimum bearing dimensions:	3.5 in x	1.27 in

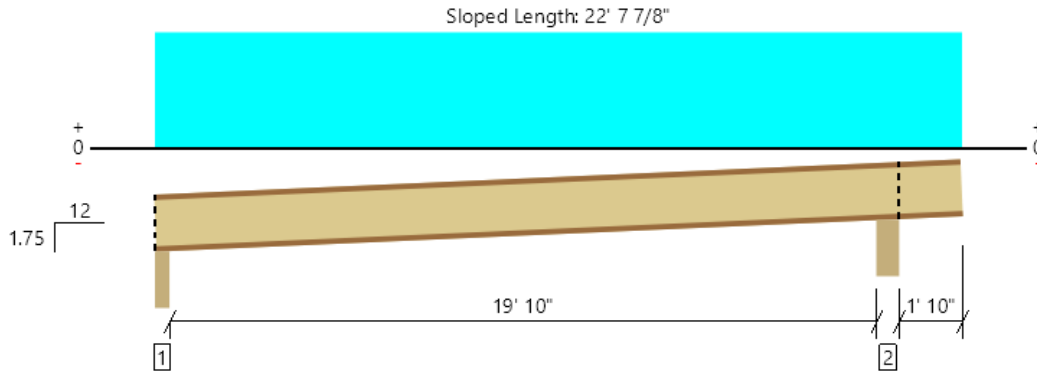
Roof, R14: South Cantilevered Roof Joists  
 1 piece(s) 11 7/8" TJI @ 210 @ 24" OC

All locations are measured from the outside face of left support (or left cantilever end). All dimensions are horizontal.

Member Length : 22' 9 9/16"

Design Results	Actual @ Location	Allowed	Result	LDF	Load: Combination (Pattern)
Member Reaction (lbs)	820 @ 2 1/2"	1679 (3.50")	Passed (49%)	1.15	1.0 D + 1.0 S (Alt Spans)
Shear (lbs)	796 @ 3 1/2"	1903	Passed (42%)	1.15	1.0 D + 1.0 S (Alt Spans)
Moment (Ft-lbs)	4016 @ 10' 2 1/2"	4364	Passed (92%)	1.15	1.0 D + 1.0 S (Alt Spans)
Live Load Defl. (in)	0.639 @ 10' 3 3/16"	1.018	Passed (L/382)	--	1.0 D + 1.0 S (Alt Spans)
Total Load Defl. (in)	1.022 @ 10' 3 1/16"	1.357	Passed (L/239)	--	1.0 D + 1.0 S (Alt Spans)

 System : Roof  
 Member Type : Joist  
 Building Use : Residential  
 Building Code : IBC 2018  
 Design Methodology : ASD  
 Member Pitch : 1.75/12

- Deflection criteria: LL (L/240) and TL (L/180).
- Overhang deflection criteria: LL (2L/240) and TL (2L/180).
- Upward deflection on right cantilever exceeds overhang deflection criteria.
- Allowed moment does not reflect the adjustment for the beam stability factor.

Supports	Bearing Length			Loads to Supports (lbs)			Accessories
	Total	Available	Required	Dead	Snow	Factored	
1 - Beveled Plate - SPF	3.50"	3.50"	1.75"	308	511	820	Blocking
2 - Beveled Plate - SPF	5.50"	5.50"	3.50"	371	612	983	Blocking

- Blocking Panels are assumed to carry no loads applied directly above them and the full load is applied to the member being designed.

Lateral Bracing	Bracing Intervals	Comments
Top Edge (Lu)	3' 6" o/c	
Bottom Edge (Lu)	8' 8" o/c	

- TJI joists are only analyzed using Maximum Allowable bracing solutions.
- Maximum allowable bracing intervals based on applied load.

Vertical Load	Location	Spacing	Dead (0.90)	Snow (1.15)	Comments
1 - Uniform (PSF)	0 to 22' 5"	24"	15.0	25.0	Default Load

**Weyerhaeuser Notes**

Weyerhaeuser warrants that the sizing of its products will be in accordance with Weyerhaeuser product design criteria and published design values. Weyerhaeuser expressly disclaims any other warranties related to the software. Use of this software is not intended to circumvent the need for a design professional as determined by the authority having jurisdiction. The designer of record, builder or framer is responsible to assure that this calculation is compatible with the overall project. Accessories (Rim Board, Blocking Panels and Squash Blocks) are not designed by this software. Products manufactured at Weyerhaeuser facilities are third-party certified to sustainable forestry standards. Weyerhaeuser Engineered Lumber Products have been evaluated by ICC-ES under evaluation reports ESR-1153 and ESR-1387 and/or tested in accordance with applicable ASTM standards. For current code evaluation reports, Weyerhaeuser product literature and installation details refer to [www.weyerhaeuser.com/woodproducts/document-library](http://www.weyerhaeuser.com/woodproducts/document-library).

The product application, input design loads, dimensions and support information have been provided by ForteWEB Software Operator

ForteWEB Software Operator	Job Notes
William Nocka CSES (978) 503-9935 11wnocka@gmail.com	



John S. Apolis, P.E. CSES, Inc.

Job number: 2022.136

Project: Li Residence

Date: 13-Oct-22

Designer: Shawn Sullivan

Page number: R15

**BEAM DESIGN (Uniform Load+Concentrated Load)**

2018 International Building Code (IBC)

2018 NDS

**Beam Description: West Rim Above Entry**

Fully Supported:	1	Snow Load:	1	Wind Load:	
Repetitive Member:		P.T. Lumber:		Wet Use:	

**Geometry and Loads:**

Span:	14 ft	Tributary Width:	1 ft	P Location:	12.25 ft
Add'l uniform DL:		DL unit load:	15 psf	Concentrated DL:	165 lbs
Add'l uniform LL:		LL unit load:		Concentrated LL:	
Add'l uniform SL:		SL unit load:	25 psf	Concentrated SL:	275 lbs
Add'l uniform WL:		WL unit load:		Concentrated WL:	

DL Reaction 1:	249 lbs	DL Reaction 2:	126 lbs	Note: Design automatically uses
LL Reaction 1:	0 lbs	LL Reaction 2:	0 lbs	ASD load combinations
SL Reaction 1:	416 lbs	SL Reaction 2:	209 lbs	
WL Reaction 1:	0 lbs	WL Reaction 2:	0 lbs	
Total Reaction 1:	<b>665 lbs</b>	Total Reaction 2:	<b>335 lbs</b>	

**Material Properties:**

E	2 msi	E'	2 msi
Fb	2600 psi	Fb'	2994 psi
Fv	285 psi	Fv'	328 psi
Fc perp	750 psi	Fc perp'	750 psi
Emin	1.016 msi	Emin'	1.016 msi

**Deflection analysis:**

For total load: Allowed deflection criteria, span/	240		
For LL only: Allowed deflection criteria, span/	360		
Max. allowed total defl:	0.7 in	Max LL defl:	0.47 in
Total defl. * I:	25.46 in^4	Required I:	36.37 in^4
LL defl. * I:	15.91 in^4	Required I:	34.09 in^4
Actual deflections:	TOTAL: 0.1 in		0.07 in

**Force analysis:**

Max. moment:	1403 ft-lb	Max Shear:	665 lbs
--------------	------------	------------	---------

**Selected Member: (1) LVL 1.75 x 11.875**

<b>Member properties:</b>	<b>Provided:</b>	<b>Required:</b>
Moment of inertia:	244.21 in^4	36.37 in^4
Section Modulus:	41.13 in^3	5.62 in^3
Section Area:	20.78 in^2	3.04 in^2
Bearing Area:		0.89 in^2
Minimum bearing dimensions:	1.75 in x	0.51 in



Roof, R16: West Rim Joist  
 1 piece(s) 1 3/4" x 11 7/8" 2.0E Microllam® LVL

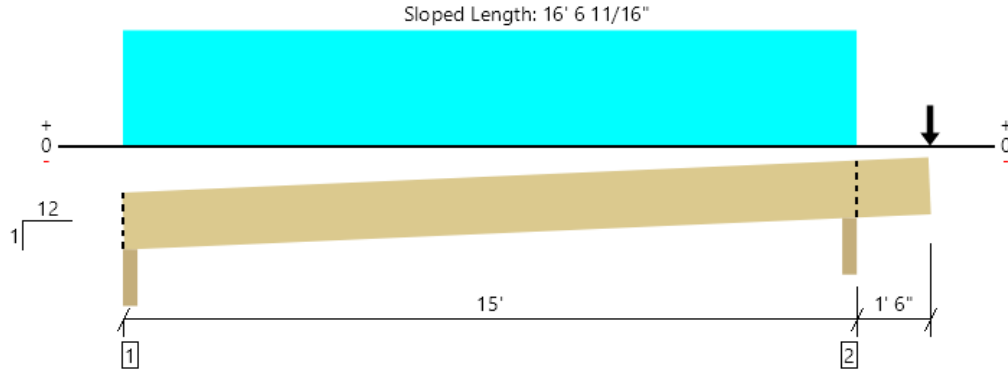

All locations are measured from the outside face of left support (or left cantilever end). All dimensions are horizontal.

Member Length : 16' 7 11/16"

Design Results	Actual @ Location	Allowed	Result	LDF	Load: Combination (Pattern)
Member Reaction (lbs)	728 @ 14' 10 1/4"	2612 (3.50")	Passed (28%)	--	1.0 D + 1.0 S (All Spans)
Shear (lbs)	338 @ 15' 11 13/16"	4541	Passed (7%)	1.15	1.0 D + 1.0 S (All Spans)
Moment (Ft-lbs)	1058 @ 6' 11 1/4"	10263	Passed (10%)	1.15	1.0 D + 1.0 S (All Spans)
Live Load Defl. (in)	0.049 @ 7' 3 15/16"	0.737	Passed (L/999+)	--	1.0 D + 1.0 S (All Spans)
Total Load Defl. (in)	0.088 @ 7' 3 7/16"	0.983	Passed (L/999+)	--	1.0 D + 1.0 S (All Spans)

System : Roof  
 Member Type : Flush Beam  
 Building Use : Residential  
 Building Code : IBC 2018  
 Design Methodology : ASD  
 Member Pitch : 1/12

- Deflection criteria: LL (L/240) and TL (L/180).
- Overhang deflection criteria: LL (2L/240) and TL (2L/180).
- Allowed moment does not reflect the adjustment for the beam stability factor.

Supports	Bearing Length			Loads to Supports (lbs)			Accessories
	Total	Available	Required	Dead	Snow	Factored	
1 - Beveled Plate - SPF	3.50"	3.50"	1.50"	144	176	320	Blocking
2 - Beveled Plate - SPF	3.50"	3.50"	1.50"	308	420	728	Blocking

• Blocking Panels are assumed to carry no loads applied directly above them and the full load is applied to the member being designed.

Lateral Bracing	Bracing Intervals	Comments
Top Edge (Lu)	16' 7" o/c	
Bottom Edge (Lu)	16' 7" o/c	

•Maximum allowable bracing intervals based on applied load.

Vertical Loads	Location (Side)	Tributary Width	Dead (0.90)	Snow (1.15)	Comments
0 - Self Weight (PLF)	0 to 16' 6"	N/A	6.1	--	
1 - Uniform (PSF)	0 to 15'	1'	15.0	25.0	Default Load
2 - Point (lb)	16' 6"	N/A	126	209	

**Weyerhaeuser Notes**

Weyerhaeuser warrants that the sizing of its products will be in accordance with Weyerhaeuser product design criteria and published design values. Weyerhaeuser expressly disclaims any other warranties related to the software. Use of this software is not intended to circumvent the need for a design professional as determined by the authority having jurisdiction. The designer of record, builder or framer is responsible to assure that this calculation is compatible with the overall project. Accessories (Rim Board, Blocking Panels and Squash Blocks) are not designed by this software. Products manufactured at Weyerhaeuser facilities are third-party certified to sustainable forestry standards. Weyerhaeuser Engineered Lumber Products have been evaluated by ICC-ES under evaluation reports ESR-1153 and ESR-1387 and/or tested in accordance with applicable ASTM standards. For current code evaluation reports, Weyerhaeuser product literature and installation details refer to [www.weyerhaeuser.com/woodproducts/document-library](http://www.weyerhaeuser.com/woodproducts/document-library).

The product application, input design loads, dimensions and support information have been provided by ForteWEB Software Operator

ForteWEB Software Operator	Job Notes
William Nocka CSES (978) 503-9935 11wnocka@gmail.com	



Roof, R17: Cantilever Flush Beam Above Entry  
 1 piece(s) 3 1/2" x 11 7/8" 2.2E Parallam® PSL

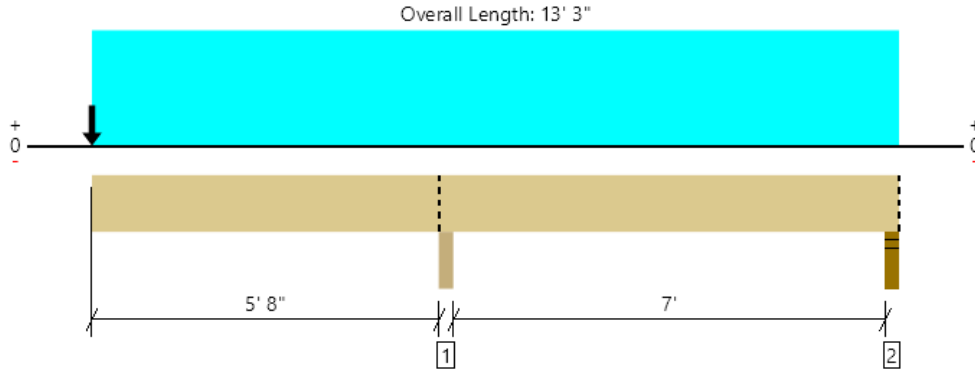

All locations are measured from the outside face of left support (or left cantilever end). All dimensions are horizontal.

Design Results	Actual @ Location	Allowed	Result	LDF	Load: Combination (Pattern)
Member Reaction (lbs)	5230 @ 5' 9 3/4"	7656 (3.50")	Passed (68%)	--	1.0 D + 1.0 S (All Spans)
Shear (lbs)	2285 @ 4' 8 1/8"	9241	Passed (25%)	1.15	1.0 D + 1.0 S (All Spans)
Moment (Ft-lbs)	-9857 @ 5' 9 3/4"	22888	Passed (43%)	1.15	1.0 D + 1.0 S (All Spans)
Live Load Defl. (in)	0.222 @ 0	0.581	Passed (2L/630)	--	1.0 D + 1.0 S (Alt Spans)
Total Load Defl. (in)	0.366 @ 0	0.775	Passed (2L/380)	--	1.0 D + 1.0 S (Alt Spans)

System : Roof  
 Member Type : Flush Beam  
 Building Use : Residential  
 Building Code : IBC 2018  
 Design Methodology : ASD  
 Member Pitch : 0/12

- Deflection criteria: LL (L/240) and TL (L/180).
- Overhang deflection criteria: LL (2L/240) and TL (2L/180).
- Left cantilever length exceeds 1/3 member length or 1/2 back span length. Additional bracing should be considered.
- Allowed moment does not reflect the adjustment for the beam stability factor.
- -470 lbs uplift at support located at 13' 1". Strapping or other restraint may be required.

Supports	Bearing Length			Loads to Supports (lbs)			Accessories
	Total	Available	Required	Dead	Snow	Factored	
1 - Column - DF	3.50"	3.50"	2.39"	2120	3110	5230	Blocking
2 - Stud wall - SPF	3.50"	3.50"	1.50"	-50	360/-420	311/-470	Blocking

• Blocking Panels are assumed to carry no loads applied directly above them and the full load is applied to the member being designed.

Lateral Bracing	Bracing Intervals	Comments
Top Edge (Lu)	13' 3" o/c	
Bottom Edge (Lu)	13' 3" o/c	

•Maximum allowable bracing intervals based on applied load.

Vertical Loads	Location (Side)	Tributary Width	Dead (0.90)	Snow (1.15)	Comments
0 - Self Weight (PLF)	0 to 13' 3"	N/A	13.0	--	
1 - Uniform (PSF)	0 to 13' 3" (Front)	8'	15.0	25.0	Default Load
2 - Point (lb)	0 (Front)	N/A	308	420	

**Weyerhaeuser Notes**

Weyerhaeuser warrants that the sizing of its products will be in accordance with Weyerhaeuser product design criteria and published design values. Weyerhaeuser expressly disclaims any other warranties related to the software. Use of this software is not intended to circumvent the need for a design professional as determined by the authority having jurisdiction. The designer of record, builder or framer is responsible to assure that this calculation is compatible with the overall project. Accessories (Rim Board, Blocking Panels and Squash Blocks) are not designed by this software. Products manufactured at Weyerhaeuser facilities are third-party certified to sustainable forestry standards. Weyerhaeuser Engineered Lumber Products have been evaluated by ICC-ES under evaluation reports ESR-1153 and ESR-1387 and/or tested in accordance with applicable ASTM standards. For current code evaluation reports, Weyerhaeuser product literature and installation details refer to [www.weyerhaeuser.com/woodproducts/document-library](http://www.weyerhaeuser.com/woodproducts/document-library).

The product application, input design loads, dimensions and support information have been provided by ForteWEB Software Operator

ForteWEB Software Operator	Job Notes
William Nocka CSES (978) 503-9935 11wnocka@gmail.com	



Roof, R18: West Cantilever Flush Beam @ Valley  
 1 piece(s) 3 1/2" x 11 7/8" 2.2E Parallam® PSL

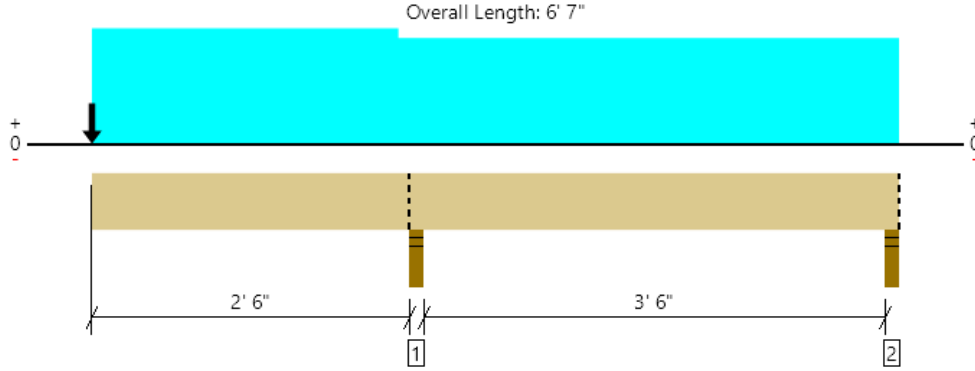

All locations are measured from the outside face of left support (or left cantilever end). All dimensions are horizontal.

Design Results	Actual @ Location	Allowed	Result	LDF	Load: Combination (Pattern)
Member Reaction (lbs)	4431 @ 2' 7 3/4"	5206 (3.50")	Passed (85%)	--	1.0 D + 1.0 S (All Spans)
Shear (lbs)	1431 @ 1' 6 1/8"	9241	Passed (15%)	1.15	1.0 D + 1.0 S (All Spans)
Moment (Ft-lbs)	-3422 @ 2' 7 3/4"	22888	Passed (15%)	1.15	1.0 D + 1.0 S (All Spans)
Live Load Defl. (in)	0.020 @ 0	0.265	Passed (2L/999+)	--	1.0 D + 1.0 S (Alt Spans)
Total Load Defl. (in)	0.033 @ 0	0.353	Passed (2L/999+)	--	1.0 D + 1.0 S (Alt Spans)

System : Roof  
 Member Type : Flush Beam  
 Building Use : Residential  
 Building Code : IBC 2018  
 Design Methodology : ASD  
 Member Pitch : 0/12

- Deflection criteria: LL (L/240) and TL (L/180).
- Overhang deflection criteria: LL (2L/240) and TL (2L/180).
- Left cantilever length exceeds 1/3 member length or 1/2 back span length. Additional bracing should be considered.
- Allowed moment does not reflect the adjustment for the beam stability factor.

Supports	Bearing Length			Loads to Supports (lbs)			Accessories
	Total	Available	Required	Dead	Snow	Factored	
1 - Stud wall - SPF	3.50"	3.50"	2.98"	1748	2683	4431	Blocking
2 - Stud wall - SPF	3.50"	3.50"	1.50"	169	575/-119	745	Blocking

• Blocking Panels are assumed to carry no loads applied directly above them and the full load is applied to the member being designed.

Lateral Bracing	Bracing Intervals	Comments
Top Edge (Lu)	6' 7" o/c	
Bottom Edge (Lu)	6' 7" o/c	

•Maximum allowable bracing intervals based on applied load.

Vertical Loads	Location (Side)	Tributary Width	Dead (0.90)	Snow (1.15)	Comments
0 - Self Weight (PLF)	0 to 6' 7"	N/A	13.0	--	
1 - Uniform (PSF)	0 to 2' 6" (Front)	18'	15.0	25.0	Default Load
2 - Point (lb)	0 (Front)	N/A	146	178	
3 - Uniform (PSF)	2' 6" to 6' 7" (Front)	16' 6"	15.0	25.0	Default Load

**Weyerhaeuser Notes**

Weyerhaeuser warrants that the sizing of its products will be in accordance with Weyerhaeuser product design criteria and published design values. Weyerhaeuser expressly disclaims any other warranties related to the software. Use of this software is not intended to circumvent the need for a design professional as determined by the authority having jurisdiction. The designer of record, builder or framer is responsible to assure that this calculation is compatible with the overall project. Accessories (Rim Board, Blocking Panels and Squash Blocks) are not designed by this software. Products manufactured at Weyerhaeuser facilities are third-party certified to sustainable forestry standards. Weyerhaeuser Engineered Lumber Products have been evaluated by ICC-ES under evaluation reports ESR-1153 and ESR-1387 and/or tested in accordance with applicable ASTM standards. For current code evaluation reports, Weyerhaeuser product literature and installation details refer to [www.weyerhaeuser.com/woodproducts/document-library](http://www.weyerhaeuser.com/woodproducts/document-library).

The product application, input design loads, dimensions and support information have been provided by ForteWEB Software Operator

ForteWEB Software Operator	Job Notes
William Nocka CSES (978) 503-9935 11wnocka@gmail.com	



John S. Apolis, P.E.

CSES, Inc.

Job number: 2022.136

Project: Li Residence

Date: 13-Oct-22

Designer: Shawn Sullivan

Page number: R19

**Post Design (Combined Axial and Moment Loading)**

2018 International Building Code (IBC)

2018 NDS

**Post Description: Beam R17 West Support**

Snow Load:	1	Wind Load:	
Repetitive Member:		P.T. Lumber:	

**Geometry and loads:**

Height	11 ft	w(d)	0 plf	M(d)	
Axial Load	5120 lbs	w(b)	0 plf	M(b)	0 ft-lbs
Le(d)	0.5 ft	Le(b)	0.5 ft		

**Material Properties:**

Fb1	900 psi	Fb(d)'	1035 psi
Fb2	900 psi	Fb(b)'	1035 psi
Fc	1350 psi	Fc'	1549.5 psi
E	1.6 msi	E'	1.6 msi
Emin	0.58 msi	Emin'	0.58 msi

**Selected Member: DF #2 3.5 x 5.5**

**Member properties:**

Section Modulus (d):	17.6 in^3
Section Modulus (b):	11.2 in^3
Section Area:	19.3 in^2

**Variables:**

Rb(d)	0.83
Rb(b)	1.64
c	0.8

**Member stresses: Provided**

FcE(d)	400611 psi	>
FcE(b)	162231 psi	>
FbE	258364 psi	>
FbE	258364 psi	>

**Required**

fc	266 psi	OK
fc	266 psi	OK
fb(d)	0 psi	OK
fb(b)	0 psi	OK

**Bending and Axial Compression Check:**

NDS 2018 EQ 3.9-3 0.03 < 1.0 **OK**

John S. Apolis, P.E. CSES, Inc.

Job number: 2022.136

Project: Li Residence

Date: 13-Oct-22

Designer: Shawn Sullivan

Page number: R20

**BEAM DESIGN (Uniform Load+Concentrated Load)**

2018 International Building Code (IBC)

2018 NDS

**Beam Description: Typical Roof Level Header**

Fully Supported:	1	Snow Load:	1	Wind Load:	
Repetitive Member:		P.T. Lumber:		Wet Use:	

**Geometry and Loads:**

Span:	5.25 ft	Tributary Width:	2 ft	P Location:	3.75 ft
Add'l uniform DL:		DL unit load:	15 psf	Concentrated DL:	
Add'l uniform LL:		LL unit load:		Concentrated LL:	
Add'l uniform SL:		SL unit load:	25 psf	Concentrated SL:	
Add'l uniform WL:		WL unit load:		Concentrated WL:	

DL Reaction 1:	79 lbs	DL Reaction 2:	79 lbs	Note: Design automatically uses ASD load combinations
LL Reaction 1:	0 lbs	LL Reaction 2:	0 lbs	
SL Reaction 1:	131 lbs	SL Reaction 2:	131 lbs	
WL Reaction 1:	0 lbs	WL Reaction 2:	0 lbs	
Total Reaction 1:	<b>210 lbs</b>	Total Reaction 2:	<b>210 lbs</b>	

**Material Properties:**

E	1.3 msi	E'	1.3 msi
Fb	850 psi	Fb'	1173 psi
Fv	150 psi	Fv'	173 psi
Fc perp	405 psi	Fc perp'	405 psi
Emin	0.47 msi	Emin'	0.47 msi

**Deflection analysis:**

For total load: Allowed deflection criteria, span/	240		
For LL only: Allowed deflection criteria, span/	360		
Max. allowed total defl:	0.26 in	Max LL defl:	0.18 in
Total defl. * I:	1.05 in^4	Required I:	4.01 in^4
LL defl. * I:	0.66 in^4	Required I:	3.76 in^4
Actual deflections:	TOTAL: 0.01 in		0.01 in

**Force analysis:**

Max. moment:	276 ft-lb	Max Shear:	210 lbs
--------------	-----------	------------	---------

**Selected Member: (2) HF #2 1.5 x 7.25**

<b>Member properties:</b>	<b>Provided:</b>	<b>Required:</b>
Moment of inertia:	95.27 in^4	4.01 in^4
Section Modulus:	26.28 in^3	2.82 in^3
Section Area:	21.75 in^2	1.83 in^2
Bearing Area:		0.52 in^2
Minimum bearing dimensions:	3. in x	0.17 in

John S. Apolis, P.E. CSES, Inc.

Job number: 2022.136

Project: Li Residence

Date: 13-Oct-22

Designer: Shawn Sullivan

Page number: R21

**BEAM DESIGN (Uniform Load+Concentrated Load)**

2018 International Building Code (IBC)

2018 NDS

**Beam Description: Interior Header North Roof**

Fully Supported:	1	Snow Load:	1	Wind Load:	
Repetitive Member:		P.T. Lumber:		Wet Use:	

**Geometry and Loads:**

Span:	3.5 ft	Tributary Width:	19 ft	P Location:	3.75 ft
Add'l uniform DL:		DL unit load:	15 psf	Concentrated DL:	
Add'l uniform LL:		LL unit load:		Concentrated LL:	
Add'l uniform SL:		SL unit load:	25 psf	Concentrated SL:	
Add'l uniform WL:		WL unit load:		Concentrated WL:	

DL Reaction 1:	499 lbs	DL Reaction 2:	499 lbs	Note: Design automatically uses
LL Reaction 1:	0 lbs	LL Reaction 2:	0 lbs	ASD load combinations
SL Reaction 1:	831 lbs	SL Reaction 2:	831 lbs	
WL Reaction 1:	0 lbs	WL Reaction 2:	0 lbs	
Total Reaction 1:	<b>1330 lbs</b>	Total Reaction 2:	<b>1330 lbs</b>	

**Material Properties:**

E	1.3 msi	E'	1.3 msi
Fb	850 psi	Fb'	1173 psi
Fv	150 psi	Fv'	173 psi
Fc perp	405 psi	Fc perp'	405 psi
Emin	0.47 msi	Emin'	0.47 msi

**Deflection analysis:**

For total load: Allowed deflection criteria, span/	240		
For LL only: Allowed deflection criteria, span/	360		
Max. allowed total defl:	0.18 in	Max LL defl:	0.12 in
Total defl. * I:	1.97 in^4	Required I:	11.28 in^4
LL defl. * I:	1.23 in^4	Required I:	10.57 in^4
Actual deflections:	TOTAL: 0.02 in		0.01 in

**Force analysis:**

Max. moment:	1164 ft-lb	Max Shear:	1330 lbs
--------------	------------	------------	----------

**Selected Member: (2) HF #2 1.5 x 7.25**

<b>Member properties:</b>	<b>Provided:</b>	<b>Required:</b>
Moment of inertia:	95.27 in^4	11.28 in^4
Section Modulus:	26.28 in^3	11.91 in^3
Section Area:	21.75 in^2	11.57 in^2
Bearing Area:		3.28 in^2
Minimum bearing dimensions:	3. in x	1.09 in

Upper Floor, U1: North East Flush Beam  
 1 piece(s) 3 1/2" x 16" 2.2E Parallam® PSL

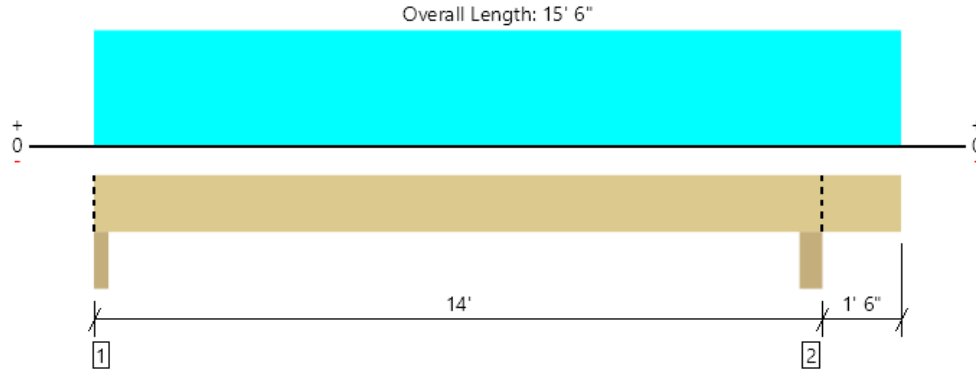

All locations are measured from the outside face of left support (or left cantilever end). All dimensions are horizontal.

Design Results	Actual @ Location	Allowed	Result	LDF	Load: Combination (Pattern)
Member Reaction (lbs)	3646 @ 2"	7656 (3.50")	Passed (48%)	--	1.0 D + 1.0 S (Alt Spans)
Shear (lbs)	2833 @ 12' 2 1/2"	12451	Passed (23%)	1.15	1.0 D + 1.0 S (All Spans)
Moment (Ft-lbs)	11949 @ 6' 10 5/8"	40198	Passed (30%)	1.15	1.0 D + 1.0 S (Alt Spans)
Live Load Defl. (in)	0.083 @ 6' 11 3/8"	0.340	Passed (L/999+)	--	1.0 D + 1.0 S (Alt Spans)
Total Load Defl. (in)	0.174 @ 6' 11 1/4"	0.680	Passed (L/941)	--	1.0 D + 1.0 S (Alt Spans)

System : Floor  
 Member Type : Flush Beam  
 Building Use : Residential  
 Building Code : IBC 2018  
 Design Methodology : ASD

- Deflection criteria: LL (L/480) and TL (L/240).
- Overhang deflection criteria: LL (2L/480) and TL (2L/240).
- Allowed moment does not reflect the adjustment for the beam stability factor.

Supports	Bearing Length			Loads to Supports (lbs)				Accessories
	Total	Available	Required	Dead	Floor Live	Snow	Factored	
1 - Column - DF	3.50"	3.50"	1.67"	1917	372/-6	1728	3646	Blocking
2 - Column - DF	5.50"	5.50"	2.09"	2415	461	2160	4575	Blocking

- Blocking Panels are assumed to carry no loads applied directly above them and the full load is applied to the member being designed.

Lateral Bracing	Bracing Intervals	Comments
Top Edge (Lu)	15' 6" o/c	
Bottom Edge (Lu)	15' 6" o/c	

- Maximum allowable bracing intervals based on applied load.

Vertical Loads	Location (Side)	Tributary Width	Dead (0.90)	Floor Live (1.00)	Snow (1.15)	Comments
0 - Self Weight (PLF)	0 to 15' 6"	N/A	17.5	--	--	
1 - Uniform (PSF)	0 to 15' 6" (Front)	1' 4"	12.0	40.0	-	Default Load
2 - Uniform (PSF)	0 to 15' 6" (Top)	12'	8.0	-	-	Wall
3 - Uniform (PSF)	0 to 15' 6" (Top)	10'	15.0	-	25.0	Roof

### Weyerhaeuser Notes

Weyerhaeuser warrants that the sizing of its products will be in accordance with Weyerhaeuser product design criteria and published design values. Weyerhaeuser expressly disclaims any other warranties related to the software. Use of this software is not intended to circumvent the need for a design professional as determined by the authority having jurisdiction. The designer of record, builder or framer is responsible to assure that this calculation is compatible with the overall project. Accessories (Rim Board, Blocking Panels and Squash Blocks) are not designed by this software. Products manufactured at Weyerhaeuser facilities are third-party certified to sustainable forestry standards. Weyerhaeuser Engineered Lumber Products have been evaluated by ICC-ES under evaluation reports ESR-1153 and ESR-1387 and/or tested in accordance with applicable ASTM standards. For current code evaluation reports, Weyerhaeuser product literature and installation details refer to [www.weyerhaeuser.com/woodproducts/document-library](http://www.weyerhaeuser.com/woodproducts/document-library).

The product application, input design loads, dimensions and support information have been provided by ForteWEB Software Operator

ForteWEB Software Operator	Job Notes
William Nocka CSES (978) 503-9935 11wnocka@gmail.com	



Upper Floor, U2: North West Flush Beam  
 1 piece(s) 3 1/2" x 16" 2.2E Parallam® PSL

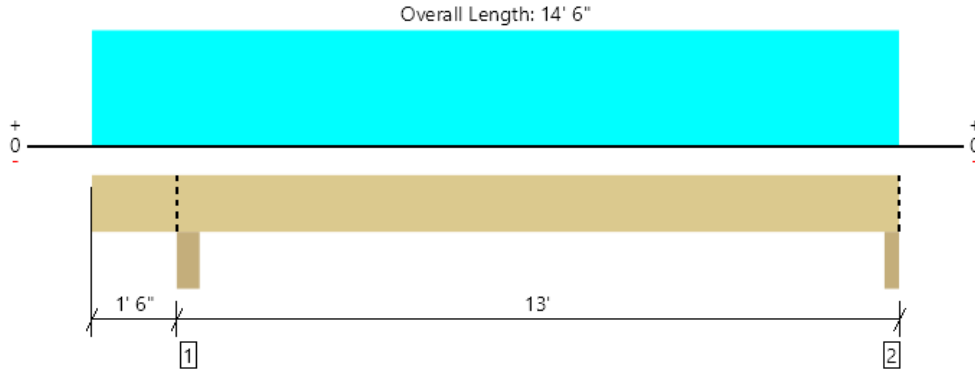

All locations are measured from the outside face of left support (or left cantilever end). All dimensions are horizontal.

Design Results	Actual @ Location	Allowed	Result	LDF	Load: Combination (Pattern)
Member Reaction (lbs)	3377 @ 14' 4"	7656 (3.50")	Passed (44%)	--	1.0 D + 1.0 S (Alt Spans)
Shear (lbs)	2572 @ 3' 3 1/2"	12451	Passed (21%)	1.15	1.0 D + 1.0 S (All Spans)
Moment (Ft-lbs)	10215 @ 8' 1 7/16"	40198	Passed (25%)	1.15	1.0 D + 1.0 S (Alt Spans)
Live Load Defl. (in)	0.062 @ 8' 5/8"	0.315	Passed (L/999+)	--	1.0 D + 1.0 S (Alt Spans)
Total Load Defl. (in)	0.130 @ 8' 3/4"	0.630	Passed (L/999+)	--	1.0 D + 1.0 S (Alt Spans)

System : Floor  
 Member Type : Flush Beam  
 Building Use : Residential  
 Building Code : IBC 2018  
 Design Methodology : ASD

- Deflection criteria: LL (L/480) and TL (L/240).
- Overhang deflection criteria: LL (2L/480) and TL (2L/240).
- Allowed moment does not reflect the adjustment for the beam stability factor.

Supports	Bearing Length			Loads to Supports (lbs)				Accessories
	Total	Available	Required	Dead	Floor Live	Snow	Factored	
1 - Column - DF	5.50"	5.50"	1.97"	2278	435	2037	4315	Blocking
2 - Column - DF	3.50"	3.50"	1.54"	1775	345/-6	1602	3377	Blocking

• Blocking Panels are assumed to carry no loads applied directly above them and the full load is applied to the member being designed.

Lateral Bracing	Bracing Intervals	Comments
Top Edge (Lu)	14' 6" o/c	
Bottom Edge (Lu)	14' 6" o/c	

•Maximum allowable bracing intervals based on applied load.

Vertical Loads	Location (Side)	Tributary Width	Dead (0.90)	Floor Live (1.00)	Snow (1.15)	Comments
0 - Self Weight (PLF)	0 to 14' 6"	N/A	17.5	--	--	
1 - Uniform (PSF)	0 to 14' 6" (Front)	1' 4"	12.0	40.0	-	Default Load
2 - Uniform (PSF)	0 to 14' 6" (Top)	12'	8.0	-	-	Wall
3 - Uniform (PSF)	0 to 14' 6" (Top)	10'	15.0	-	25.0	Roof

**Weyerhaeuser Notes**

Weyerhaeuser warrants that the sizing of its products will be in accordance with Weyerhaeuser product design criteria and published design values. Weyerhaeuser expressly disclaims any other warranties related to the software. Use of this software is not intended to circumvent the need for a design professional as determined by the authority having jurisdiction. The designer of record, builder or framer is responsible to assure that this calculation is compatible with the overall project. Accessories (Rim Board, Blocking Panels and Squash Blocks) are not designed by this software. Products manufactured at Weyerhaeuser facilities are third-party certified to sustainable forestry standards. Weyerhaeuser Engineered Lumber Products have been evaluated by ICC-ES under evaluation reports ESR-1153 and ESR-1387 and/or tested in accordance with applicable ASTM standards. For current code evaluation reports, Weyerhaeuser product literature and installation details refer to [www.weyerhaeuser.com/woodproducts/document-library](http://www.weyerhaeuser.com/woodproducts/document-library).

The product application, input design loads, dimensions and support information have been provided by ForteWEB Software Operator

ForteWEB Software Operator	Job Notes
William Nocka CSES (978) 503-9935 11wnocka@gmail.com	





John S. Apolis, P.E. CSES, Inc.

Job number: 2022.136

Project: Li Residence

Date: 13-Oct-22

Designer: Shawn Sullivan

Page number: U3

**BEAM DESIGN (Uniform Load+Concentrated Load)**

2018 International Building Code (IBC)

2018 NDS

**Beam Description: East Entrance Joist**

Fully Supported:	1	Snow Load:	1	Wind Load:	
Repetitive Member:	1	P.T. Lumber:		Wet Use:	

**Geometry and Loads:**

Span:	5.5 ft	Tributary Width:	2 ft	P Location:	3.75 ft
Add'l uniform DL:		DL unit load:	15 psf	Concentrated DL:	
Add'l uniform LL:		LL unit load:		Concentrated LL:	
Add'l uniform SL:		SL unit load:	25 psf	Concentrated SL:	
Add'l uniform WL:		WL unit load:		Concentrated WL:	

DL Reaction 1:	83 lbs	DL Reaction 2:	83 lbs	Note: Design automatically uses
LL Reaction 1:	0 lbs	LL Reaction 2:	0 lbs	ASD load combinations
SL Reaction 1:	138 lbs	SL Reaction 2:	138 lbs	
WL Reaction 1:	0 lbs	WL Reaction 2:	0 lbs	
Total Reaction 1:	<b>220 lbs</b>	Total Reaction 2:	<b>220 lbs</b>	

**Material Properties:**

E	1.3 msi	E'	1.3 msi
Fb	850 psi	Fb'	1461 psi
Fv	150 psi	Fv'	173 psi
Fc perp	405 psi	Fc perp'	405 psi
Emin	0.47 msi	Emin'	0.47 msi

**Deflection analysis:**

For total load: Allowed deflection criteria, span/	240		
For LL only: Allowed deflection criteria, span/	360		
Max. allowed total defl:	0.28 in	Max LL defl:	0.18 in
Total defl. * I:	1.27 in^4	Required I:	4.61 in^4
LL defl. * I:	0.79 in^4	Required I:	4.32 in^4
Actual deflections:	TOTAL: 0.06 in		0.04 in

**Force analysis:**

Max. moment:	303 ft-lb	Max Shear:	220 lbs
--------------	-----------	------------	---------

**Selected Member: (1) HF #2 1.5 x 5.5**

<b>Member properties:</b>	<b>Provided:</b>	<b>Required:</b>
Moment of inertia:	20.8 in^4	4.61 in^4
Section Modulus:	7.56 in^3	2.48 in^3
Section Area:	8.25 in^2	1.91 in^2
Bearing Area:		0.54 in^2
Minimum bearing dimensions:	1.5 in x	0.36 in

John S. Apolis, P.E. CSES, Inc.

Job number: 2022.136

Project: Li Residence

Date: 13-Oct-22

Designer: Shawn Sullivan

Page number: U4

**BEAM DESIGN (Uniform Load+Concentrated Load)**

2018 International Building Code (IBC)

2018 NDS

**Beam Description: East Entrance Rim**

Fully Supported:	1	Snow Load:	1	Wind Load:	
Repetitive Member:	1	P.T. Lumber:		Wet Use:	

**Geometry and Loads:**

Span:	13 ft	Tributary Width:	2.75 ft	P Location:	3.75 ft
Add'l uniform DL:		DL unit load:	15 psf	Concentrated DL:	
Add'l uniform LL:		LL unit load:		Concentrated LL:	
Add'l uniform SL:		SL unit load:	25 psf	Concentrated SL:	
Add'l uniform WL:		WL unit load:		Concentrated WL:	

DL Reaction 1:	268 lbs	DL Reaction 2:	268 lbs	Note: Design automatically uses ASD load combinations
LL Reaction 1:	0 lbs	LL Reaction 2:	0 lbs	
SL Reaction 1:	447 lbs	SL Reaction 2:	447 lbs	
WL Reaction 1:	0 lbs	WL Reaction 2:	0 lbs	
Total Reaction 1:	<b>715 lbs</b>	Total Reaction 2:	<b>715 lbs</b>	

**Material Properties:**

E	1.6 msi	E'	1.6 msi
Fb	900 psi	Fb'	1547 psi
Fv	180 psi	Fv'	207 psi
Fc perp	625 psi	Fc perp'	625 psi
Emin	0.58 msi	Emin'	0.58 msi

**Deflection analysis:**

For total load: Allowed deflection criteria, span/	240		
For LL only: Allowed deflection criteria, span/	360		
Max. allowed total defl:	0.65 in	Max LL defl:	0.43 in
Total defl. * I:	44.18 in^4	Required I:	67.97 in^4
LL defl. * I:	27.61 in^4	Required I:	63.72 in^4
Actual deflections: TOTAL:	0.4 in		0.25 in

**Force analysis:**

Max. moment:	2324 ft-lb	Max Shear:	715 lbs
--------------	------------	------------	---------

**Selected Member: (1) DF #2 3.5 x 7.25**

<b>Member properties:</b>	<b>Provided:</b>	<b>Required:</b>
Moment of inertia:	111.15 in^4	67.97 in^4
Section Modulus:	30.66 in^3	18.02 in^3
Section Area:	25.38 in^2	5.18 in^2
Bearing Area:		1.14 in^2
Minimum bearing dimensions:	3.5 in x	0.33 in

Upper Floor, U5: East Entry North Cantilever Flush Beam  
1 piece(s) 4 x 8 DF No.2

Overall Length: 6'

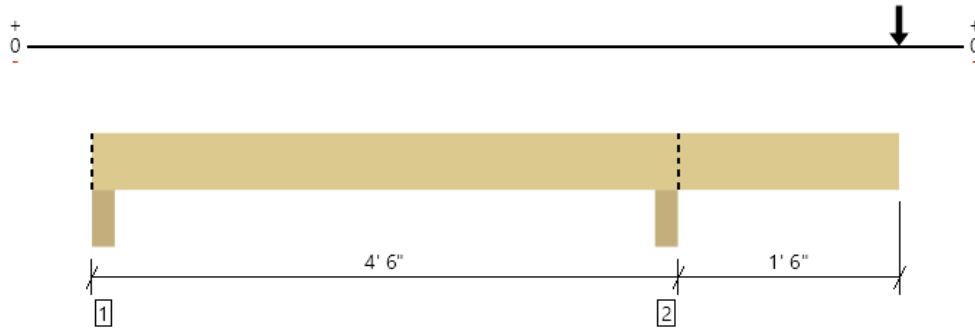

All locations are measured from the outside face of left support (or left cantilever end). All dimensions are horizontal.

Design Results	Actual @ Location	Allowed	Result	LDF	Load: Combination (Pattern)
Member Reaction (lbs)	1054 @ 4' 3 1/4"	7796 (5.50")	Passed (14%)	--	1.0 D + 1.0 S (All Spans)
Shear (lbs)	720 @ 5' 1 1/4"	3502	Passed (21%)	1.15	1.0 D + 1.0 S (All Spans)
Moment (Ft-lbs)	-1244 @ 4' 3 1/4"	3438	Passed (36%)	1.15	1.0 D + 1.0 S (All Spans)
Live Load Defl. (in)	0.025 @ 6'	0.200	Passed (2L/999+)	--	1.0 D + 1.0 S (All Spans)
Total Load Defl. (in)	0.039 @ 6'	0.200	Passed (2L/999+)	--	1.0 D + 1.0 S (All Spans)

System : Floor  
Member Type : Flush Beam  
Building Use : Residential  
Building Code : IBC 2018  
Design Methodology : ASD

- Deflection criteria: LL (L/480) and TL (L/240).
- Overhang deflection criteria: LL (0.2") and TL (0.2").
- Allowed moment does not reflect the adjustment for the beam stability factor.
- -301 lbs uplift at support located at 4". Strapping or other restraint may be required.
- Applicable calculations are based on NDS.

Supports	Bearing Length			Loads to Supports (lbs)			Accessories
	Total	Available	Required	Dead	Snow	Factored	
1 - Column - HF	5.50"	5.50"	1.50"	-105	-196	-301	Blocking
2 - Beam - HF	5.50"	5.50"	1.50"	410	643	1054	Blocking

• Blocking Panels are assumed to carry no loads applied directly above them and the full load is applied to the member being designed.

Lateral Bracing	Bracing Intervals	Comments
Top Edge (Lu)	6' o/c	
Bottom Edge (Lu)	6' o/c	

•Maximum allowable bracing intervals based on applied load.

Vertical Loads	Location (Side)	Tributary Width	Dead (0.90)	Snow (1.15)	Comments
0 - Self Weight (PLF)	0 to 6'	N/A	6.4	--	
1 - Point (lb)	6' (Front)	N/A	267	447	Default Load

**Weyerhaeuser Notes**

Weyerhaeuser warrants that the sizing of its products will be in accordance with Weyerhaeuser product design criteria and published design values. Weyerhaeuser expressly disclaims any other warranties related to the software. Use of this software is not intended to circumvent the need for a design professional as determined by the authority having jurisdiction. The designer of record, builder or framer is responsible to assure that this calculation is compatible with the overall project. Accessories (Rim Board, Blocking Panels and Squash Blocks) are not designed by this software. Products manufactured at Weyerhaeuser facilities are third-party certified to sustainable forestry standards. Weyerhaeuser Engineered Lumber Products have been evaluated by ICC-ES under evaluation reports ESR-1153 and ESR-1387 and/or tested in accordance with applicable ASTM standards. For current code evaluation reports, Weyerhaeuser product literature and installation details refer to [www.weyerhaeuser.com/woodproducts/document-library](http://www.weyerhaeuser.com/woodproducts/document-library).

The product application, input design loads, dimensions and support information have been provided by ForteWEB Software Operator

ForteWEB Software Operator	Job Notes
William Nocka CSES (978) 503-9935 11wnocka@gmail.com	



Upper Floor, U6: East Entry South Cantilever Flush Beam  
1 piece(s) 4 x 8 DF No.2

Overall Length: 11' 4"

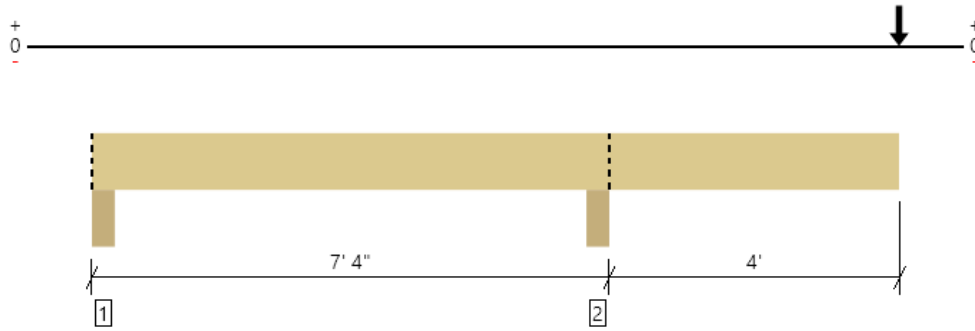

All locations are measured from the outside face of left support (or left cantilever end). All dimensions are horizontal.

Design Results	Actual @ Location	Allowed	Result	LDF	Load: Combination (Pattern)
Member Reaction (lbs)	1219 @ 7' 1 1/4"	12031 (5.50")	Passed (10%)	--	1.0 D + 1.0 S (All Spans)
Shear (lbs)	737 @ 7' 11 1/4"	3502	Passed (21%)	1.15	1.0 D + 1.0 S (All Spans)
Moment (Ft-lbs)	-3081 @ 7' 1 1/4"	3438	Passed (90%)	1.15	1.0 D + 1.0 S (All Spans)
Live Load Defl. (in)	0.285 @ 11' 4"	0.423	Passed (2L/356)	--	1.0 D + 1.0 S (All Spans)
Total Load Defl. (in)	0.460 @ 11' 4"	0.564	Passed (2L/220)	--	1.0 D + 1.0 S (All Spans)

System : Roof  
Member Type : Flush Beam  
Building Use : Residential  
Building Code : IBC 2018  
Design Methodology : ASD  
Member Pitch : 0/12

- Deflection criteria: LL (L/240) and TL (L/180).
- Overhang deflection criteria: LL (2L/240) and TL (2L/180).
- Right cantilever length exceeds 1/3 member length or 1/2 back span length. Additional bracing should be considered.
- Allowed moment does not reflect the adjustment for the beam stability factor.
- -431 lbs uplift at support located at 4". Strapping or other restraint may be required.
- Applicable calculations are based on NDS.

Supports	Bearing Length			Loads to Supports (lbs)			Accessories
	Total	Available	Required	Dead	Snow	Factored	
1 - Column - DF	5.50"	5.50"	1.50"	-152	-279	-431	Blocking
2 - Column - DF	5.50"	5.50"	1.50"	493	726	1219	Blocking

- Blocking Panels are assumed to carry no loads applied directly above them and the full load is applied to the member being designed.

Lateral Bracing	Bracing Intervals	Comments
Top Edge (Lu)	11' 4" o/c	
Bottom Edge (Lu)	11' 4" o/c	

- Maximum allowable bracing intervals based on applied load.

Vertical Loads	Location (Side)	Tributary Width	Dead (0.90)	Snow (1.15)	Comments
0 - Self Weight (PLF)	0 to 11' 4"	N/A	6.4	--	
1 - Point (lb)	11' 4" (Front)	N/A	268	447	

**Weyerhaeuser Notes**

Weyerhaeuser warrants that the sizing of its products will be in accordance with Weyerhaeuser product design criteria and published design values. Weyerhaeuser expressly disclaims any other warranties related to the software. Use of this software is not intended to circumvent the need for a design professional as determined by the authority having jurisdiction. The designer of record, builder or framer is responsible to assure that this calculation is compatible with the overall project. Accessories (Rim Board, Blocking Panels and Squash Blocks) are not designed by this software. Products manufactured at Weyerhaeuser facilities are third-party certified to sustainable forestry standards. Weyerhaeuser Engineered Lumber Products have been evaluated by ICC-ES under evaluation reports ESR-1153 and ESR-1387 and/or tested in accordance with applicable ASTM standards. For current code evaluation reports, Weyerhaeuser product literature and installation details refer to [www.weyerhaeuser.com/woodproducts/document-library](http://www.weyerhaeuser.com/woodproducts/document-library).

The product application, input design loads, dimensions and support information have been provided by ForteWEB Software Operator

ForteWEB Software Operator	Job Notes
William Nocka CSES (978) 503-9935 11wnocka@gmail.com	



John S. Apolis, P.E.

CSES, Inc.

Job number: 2022.136

Project: Li Residence

Date: 13-Oct-22

Designer: Shawn Sullivan

Page number: U7

**Post Design (Combined Axial and Moment Loading)**

2018 International Building Code (IBC)

2018 NDS

**Post Description: Beam U1/U2 Support**

Snow Load:	1	Wind Load:	
Repetitive Member:		P.T. Lumber:	

**Geometry and loads:**

Height	9.5 ft	w(d)	0 plf	M(d)	
Axial Load	7007 lbs	w(b)	0 plf	M(b)	0 ft-lbs
Le(d)	0.5 ft	Le(b)	9.5 ft		

**Material Properties:**

Fb1	900 psi	Fb(d)'	1035 psi
Fb2	900 psi	Fb(b)'	1035 psi
Fc	1350 psi	Fc'	418.5 psi
E	1.6 msi	E'	1.6 msi
Emin	0.58 msi	Emin'	0.58 msi

**Selected Member: DF #2 3.5 x 5.5**

**Member properties:**

Section Modulus (d):	17.6 in^3
Section Modulus (b):	11.2 in^3
Section Area:	19.3 in^2

**Variables:**

Rb(d)	0.83
Rb(b)	7.15
c	0.8

**Member stresses: Provided**

FcE(d)	400611 psi	>
FcE(b)	449 psi	>
FbE	13598 psi	>
FbE	13598 psi	>

**Required**

fc	364 psi	OK
fc	364 psi	OK
fb(d)	0 psi	OK
fb(b)	0 psi	OK

**Bending and Axial Compression Check:**

NDS 2018 EQ 3.9-3 0.76 < 1.0 **OK**

Upper Floor, U8: Central East Flush Beam  
1 piece(s) 3 1/2" x 16" 2.2E Parallam® PSL

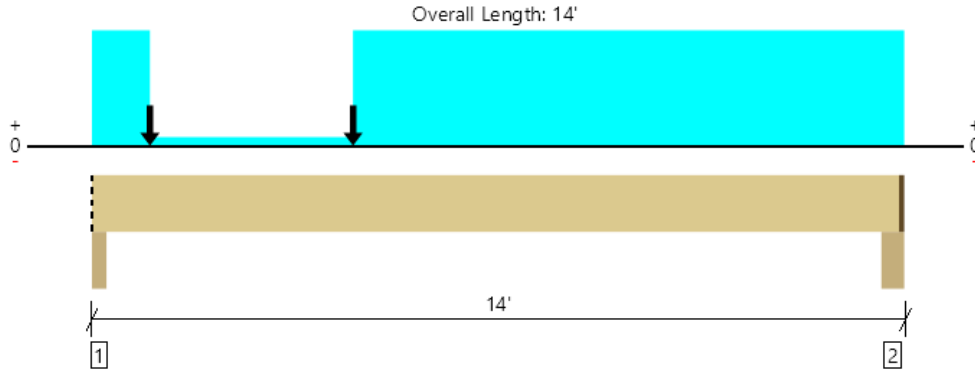

All locations are measured from the outside face of left support (or left cantilever end). All dimensions are horizontal.

Design Results	Actual @ Location	Allowed	Result	LDF	Load: Combination (Pattern)
Member Reaction (lbs)	5815 @ 2"	7656 (3.50")	Passed (76%)	--	1.0 D + 1.0 S (All Spans)
Shear (lbs)	4569 @ 12' 2 1/2"	12451	Passed (37%)	1.15	1.0 D + 1.0 S (All Spans)
Moment (Ft-lbs)	19539 @ 6' 11 3/4"	40198	Passed (49%)	1.15	1.0 D + 1.0 S (All Spans)
Live Load Defl. (in)	0.154 @ 6' 11 3/8"	0.338	Passed (L/999+)	--	1.0 D + 1.0 S (All Spans)
Total Load Defl. (in)	0.278 @ 6' 11 1/2"	0.675	Passed (L/584)	--	1.0 D + 1.0 S (All Spans)

System : Floor  
Member Type : Flush Beam  
Building Use : Residential  
Building Code : IBC 2018  
Design Methodology : ASD

- Deflection criteria: LL (L/480) and TL (L/240).
- Allowed moment does not reflect the adjustment for the beam stability factor.

Supports	Bearing Length			Loads to Supports (lbs)				Accessories
	Total	Available	Required	Dead	Floor Live	Snow	Factored	
1 - Column - DF	3.50"	3.50"	2.66"	2530	369	3285	5815	Blocking
2 - Column - DF	5.50"	4.25"	2.76"	2767	378	3364	6132	1 1/4" Rim Board

- Rim Board is assumed to carry all loads applied directly above it, bypassing the member being designed.
- Blocking Panels are assumed to carry no loads applied directly above them and the full load is applied to the member being designed.

Lateral Bracing	Bracing Intervals	Comments
Top Edge (Lu)	13' 11" o/c	
Bottom Edge (Lu)	13' 11" o/c	

- Maximum allowable bracing intervals based on applied load.

Vertical Loads	Location (Side)	Tributary Width	Dead (0.90)	Floor Live (1.00)	Snow (1.15)	Comments
0 - Self Weight (PLF)	0 to 13' 10 3/4"	N/A	17.5	--	--	
1 - Uniform (PSF)	0 to 14' (Front)	1' 4"	12.0	40.0	-	Default Load
2 - Uniform (PSF)	0 to 1' (Top)	10'	8.0	-	-	Wall
3 - Uniform (PSF)	0 to 1' (Top)	19'	15.0	-	25.0	Roof
4 - Point (lb)	1' (Front)	N/A	499	-	831	
5 - Point (lb)	4' 6" (Front)	N/A	499	-	831	
6 - Uniform (PSF)	4' 6" to 14' (Top)	10'	8.0	-	-	Wall
7 - Uniform (PSF)	4' 6" to 14' (Top)	19'	15.0	-	25.0	Roof

**Weyerhaeuser Notes**

Weyerhaeuser warrants that the sizing of its products will be in accordance with Weyerhaeuser product design criteria and published design values. Weyerhaeuser expressly disclaims any other warranties related to the software. Use of this software is not intended to circumvent the need for a design professional as determined by the authority having jurisdiction. The designer of record, builder or framer is responsible to assure that this calculation is compatible with the overall project. Accessories (Rim Board, Blocking Panels and Squash Blocks) are not designed by this software. Products manufactured at Weyerhaeuser facilities are third-party certified to sustainable forestry standards. Weyerhaeuser Engineered Lumber Products have been evaluated by ICC-ES under evaluation reports ESR-1153 and ESR-1387 and/or tested in accordance with applicable ASTM standards. For current code evaluation reports, Weyerhaeuser product literature and installation details refer to [www.weyerhaeuser.com/woodproducts/document-library](http://www.weyerhaeuser.com/woodproducts/document-library).

The product application, input design loads, dimensions and support information have been provided by ForteWEB Software Operator

ForteWEB Software Operator	Job Notes
William Nocka CSES (978) 503-9935 11wnocka@gmail.com	



Upper Floor, U9: Central West Flush Beam  
 1 piece(s) 3 1/2" x 16" 2.2E Parallam® PSL

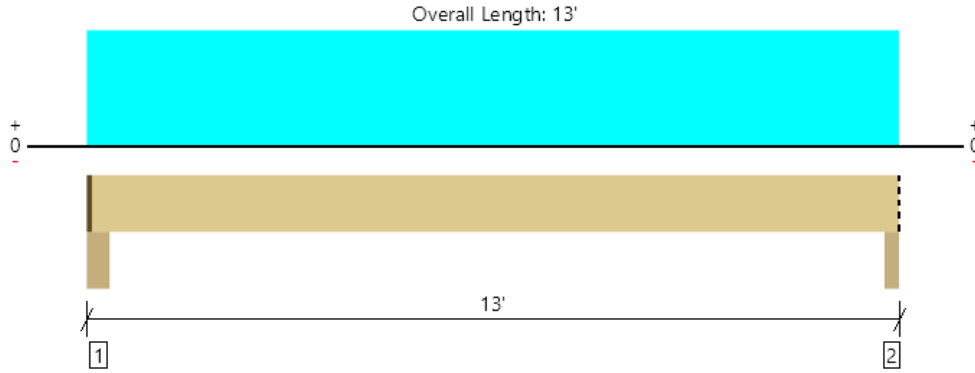

All locations are measured from the outside face of left support (or left cantilever end). All dimensions are horizontal.

Design Results	Actual @ Location	Allowed	Result	LDF	Load: Combination (Pattern)
Member Reaction (lbs)	5605 @ 12' 10"	7656 (3.50")	Passed (73%)	--	1.0 D + 1.0 S (All Spans)
Shear (lbs)	4186 @ 1' 9 1/2"	12451	Passed (34%)	1.15	1.0 D + 1.0 S (All Spans)
Moment (Ft-lbs)	17061 @ 6' 7"	40198	Passed (42%)	1.15	1.0 D + 1.0 S (All Spans)
Live Load Defl. (in)	0.117 @ 6' 7"	0.313	Passed (L/999+)	--	1.0 D + 1.0 S (All Spans)
Total Load Defl. (in)	0.214 @ 6' 7"	0.625	Passed (L/699)	--	1.0 D + 1.0 S (All Spans)

System : Floor  
 Member Type : Flush Beam  
 Building Use : Residential  
 Building Code : IBC 2018  
 Design Methodology : ASD

- Deflection criteria: LL (L/480) and TL (L/240).
- Allowed moment does not reflect the adjustment for the beam stability factor.

Supports	Bearing Length			Loads to Supports (lbs)				Accessories
	Total	Available	Required	Dead	Floor Live	Snow	Factored	
1 - Column - DF	5.50"	4.25"	2.59"	2622	351	3127	5749	1 1/4" Rim Board
2 - Column - DF	3.50"	3.50"	2.56"	2557	342	3048	5605	Blocking

- Rim Board is assumed to carry all loads applied directly above it, bypassing the member being designed.
- Blocking Panels are assumed to carry no loads applied directly above them and the full load is applied to the member being designed.

Lateral Bracing	Bracing Intervals	Comments
Top Edge (Lu)	12' 11" o/c	
Bottom Edge (Lu)	12' 11" o/c	

- Maximum allowable bracing intervals based on applied load.

Vertical Loads	Location (Side)	Tributary Width	Dead (0.90)	Floor Live (1.00)	Snow (1.15)	Comments
0 - Self Weight (PLF)	1 1/4" to 13'	N/A	17.5	--	--	
1 - Uniform (PSF)	0 to 13' (Front)	1' 4"	12.0	40.0	-	Default Load
2 - Uniform (PSF)	0 to 13' (Top)	10'	8.0	-	-	Wall
3 - Uniform (PSF)	0 to 13' (Top)	19'	15.0	-	25.0	Roof

**Weyerhaeuser Notes**

Weyerhaeuser warrants that the sizing of its products will be in accordance with Weyerhaeuser product design criteria and published design values. Weyerhaeuser expressly disclaims any other warranties related to the software. Use of this software is not intended to circumvent the need for a design professional as determined by the authority having jurisdiction. The designer of record, builder or framer is responsible to assure that this calculation is compatible with the overall project. Accessories (Rim Board, Blocking Panels and Squash Blocks) are not designed by this software. Products manufactured at Weyerhaeuser facilities are third-party certified to sustainable forestry standards. Weyerhaeuser Engineered Lumber Products have been evaluated by ICC-ES under evaluation reports ESR-1153 and ESR-1387 and/or tested in accordance with applicable ASTM standards. For current code evaluation reports, Weyerhaeuser product literature and installation details refer to [www.weyerhaeuser.com/woodproducts/document-library](http://www.weyerhaeuser.com/woodproducts/document-library).

The product application, input design loads, dimensions and support information have been provided by ForteWEB Software Operator

ForteWEB Software Operator	Job Notes
William Nocka CSES (978) 503-9935 11wnocka@gmail.com	



John S. Apolis, P.E.

CSES, Inc.

Job number: 2022.136

Project: Li Residence

Date: 13-Oct-22

Designer: Shawn Sullivan

Page number: U10

**Post Design (Combined Axial and Moment Loading)**

2018 International Building Code (IBC)

2018 NDS

**Post Description: Beam U8/U9 Support**

Snow Load:	1	Wind Load:	
Repetitive Member:		P.T. Lumber:	

**Geometry and loads:**

Height	9.5 ft	w(d)	0 plf	M(d)	
Axial Load	11647 lbs	w(b)	0 plf	M(b)	0 ft-lbs
Le(d)	9.5 ft	Le(b)	9.5 ft		

**Material Properties:**

Fb1	875 psi	Fb(d)'	1006.3 psi
Fb2	875 psi	Fb(b)'	1006.3 psi
Fc	1350 psi	Fc'	879.69 psi
E	1.6 msi	E'	1.6 msi
Emin	0.58 msi	Emin'	0.58 msi

**Selected Member: DF #2 5.5 x 5.5**

**Member properties:**

Section Modulus (d):	27.7 in^3
Section Modulus (b):	27.7 in^3
Section Area:	30.3 in^2

**Variables:**

Rb(d)	4.55
Rb(b)	4.55
c	0.8

**Member stresses: Provided**

FcE(d)	1110 psi	>
FcE(b)	1110 psi	>
FbE	33579 psi	>
FbE	33579 psi	>

**Required**

fc	385 psi	OK
fc	385 psi	OK
fb(d)	0 psi	OK
fb(b)	0 psi	OK

**Bending and Axial Compression Check:**

NDS 2018 EQ 3.9-3 0.19 < 1.0 **OK**



John S. Apolis, P.E. CSES, Inc.

Job number: 2022.136

Project: Li Residence

Date: 13-Oct-22

Designer: Shawn Sullivan

Page number: U11

**BEAM DESIGN (Uniform Load+Concentrated Load)**

2018 International Building Code (IBC)

2018 NDS

**Beam Description: West Entrance Door Header Below Beam U9**

Fully Supported:	1	Snow Load:	1	Wind Load:	
Repetitive Member:		P.T. Lumber:		Wet Use:	

**Geometry and Loads:**

Span:	5.5 ft	Tributary Width:	13.5 ft	P Location:	1 ft
Add'l uniform DL:	110 lbs/ft	DL unit load:	12 psf	Concentrated DL:	2622 lbs
Add'l uniform LL:		LL unit load:	40 psf	Concentrated LL:	342 lbs
Add'l uniform SL:	50 lbs/ft	SL unit load:		Concentrated SL:	3048 lbs
Add'l uniform WL:		WL unit load:		Concentrated WL:	

DL Reaction 1:	2893 lbs	DL Reaction 2:	1225 lbs	Note: Design automatically uses
LL Reaction 1:	1765 lbs	LL Reaction 2:	1547 lbs	ASD load combinations
SL Reaction 1:	2631 lbs	SL Reaction 2:	692 lbs	
WL Reaction 1:	0 lbs	WL Reaction 2:	0 lbs	
Total Reaction 1:	<b>6190 lbs</b>	Total Reaction 2:	<b>2904 lbs</b>	

**Material Properties:**

E	2 msi	E'	2 msi
Fb	2600 psi	Fb'	3098 psi
Fv	285 psi	Fv'	328 psi
Fc perp	750 psi	Fc perp'	750 psi
Emin	1.016 msi	Emin'	1.016 msi

**Deflection analysis:**

For total load: Allowed deflection criteria, span/	240		
For LL only: Allowed deflection criteria, span/	360		
Max. allowed total defl:	0.28 in	Max LL defl:	0.18 in
Total defl. * I:	18.46 in^4	Required I:	67.12 in^4
LL defl. * I:	11.48 in^4	Required I:	62.61 in^4
Actual deflections: TOTAL:	0.08 in		0.05 in

**Force analysis:**

Max. moment:	5784 ft-lb	Max Shear:	6190 lbs
--------------	------------	------------	----------

**Selected Member: (2) LVL 1.75 x 9.25**

<b>Member properties:</b>	<b>Provided:</b>	<b>Required:</b>
Moment of inertia:	230.84 in^4	67.12 in^4
Section Modulus:	49.91 in^3	22.41 in^3
Section Area:	32.38 in^2	28.33 in^2
Bearing Area:		8.25 in^2
Minimum bearing dimensions:	3.5 in x	2.36 in

John S. Apolis, P.E. CSES, Inc.

Job number: 2022.136

Project: Li Residence

Date: 13-Oct-22

Designer: Shawn Sullivan

Page number: U12

**BEAM DESIGN (Uniform Load+Concentrated Load)**

2018 International Building Code (IBC)

2018 NDS

**Beam Description: Header @ West Entrance Floor Opening**

Fully Supported:	1	Snow Load:	1	Wind Load:	
Repetitive Member:		P.T. Lumber:		Wet Use:	

**Geometry and Loads:**

Span:	10 ft	Tributary Width:	8.75 ft	P Location:	3.75 ft
Add'l uniform DL:		DL unit load:	12 psf	Concentrated DL:	
Add'l uniform LL:		LL unit load:	40 psf	Concentrated LL:	
Add'l uniform SL:		SL unit load:		Concentrated SL:	
Add'l uniform WL:		WL unit load:		Concentrated WL:	

DL Reaction 1:	525 lbs	DL Reaction 2:	525 lbs	Note: Design automatically uses
LL Reaction 1:	1750 lbs	LL Reaction 2:	1750 lbs	ASD load combinations
SL Reaction 1:	0 lbs	SL Reaction 2:	0 lbs	
WL Reaction 1:	0 lbs	WL Reaction 2:	0 lbs	
Total Reaction 1:	<b>2275 lbs</b>	Total Reaction 2:	<b>2275 lbs</b>	

**Material Properties:**

E	2 msi	E'	2 msi
Fb	2600 psi	Fb'	2875 psi
Fv	285 psi	Fv'	328 psi
Fc perp	750 psi	Fc perp'	750 psi
Emin	1.016 msi	Emin'	1.016 msi

**Deflection analysis:**

For total load: Allowed deflection criteria, span/	240		
For LL only: Allowed deflection criteria, span/	480		
Max. allowed total defl:	0.5 in	Max LL defl:	0.25 in
Total defl. * I:	51.19 in^4	Required I:	102.38 in^4
LL defl. * I:	39.38 in^4	Required I:	157.5 in^4
Actual deflections:	TOTAL: 0.04 in		0.03 in

**Force analysis:**

Max. moment:	5688 ft-lb	Max Shear:	2275 lbs
--------------	------------	------------	----------

**Selected Member: (2) LVL 1.75 x 16**

<b>Member properties:</b>	<b>Provided:</b>	<b>Required:</b>
Moment of inertia:	1194.67 in^4	157.5 in^4
Section Modulus:	149.33 in^3	23.74 in^3
Section Area:	56. in^2	10.41 in^2
Bearing Area:		3.03 in^2
Minimum bearing dimensions:	3.5 in x	0.87 in

John S. Apolis, P.E. CSES, Inc.

Job number: 2022.136

Project: Li Residence

Date: 13-Oct-22

Designer: Shawn Sullivan

Page number: U13

**BEAM DESIGN (Uniform Load+Concentrated Load)**

2018 International Building Code (IBC)

2018 NDS

**Beam Description: Stair Landing Flush Beam**

Fully Supported:	1	Snow Load:	1	Wind Load:	
Repetitive Member:		P.T. Lumber:		Wet Use:	

**Geometry and Loads:**

Span:	7.5 ft	Tributary Width:	4.5 ft	P Location:	3.75 ft
Add'l uniform DL:		DL unit load:	12 psf	Concentrated DL:	
Add'l uniform LL:		LL unit load:	60 psf	Concentrated LL:	
Add'l uniform SL:		SL unit load:		Concentrated SL:	
Add'l uniform WL:		WL unit load:		Concentrated WL:	

DL Reaction 1:	203 lbs	DL Reaction 2:	203 lbs	Note: Design automatically uses
LL Reaction 1:	1013 lbs	LL Reaction 2:	1013 lbs	ASD load combinations
SL Reaction 1:	0 lbs	SL Reaction 2:	0 lbs	
WL Reaction 1:	0 lbs	WL Reaction 2:	0 lbs	
Total Reaction 1:	<b>1215 lbs</b>	Total Reaction 2:	<b>1215 lbs</b>	

**Material Properties:**

E	1.3 msi	E'	1.3 msi
Fb	850 psi	Fb'	1173 psi
Fv	150 psi	Fv'	173 psi
Fc perp	405 psi	Fc perp'	405 psi
Emin	0.47 msi	Emin'	0.47 msi

**Deflection analysis:**

For total load: Allowed deflection criteria, span/	240		
For LL only: Allowed deflection criteria, span/	480		
Max. allowed total defl:	0.38 in	Max LL defl:	0.19 in
Total defl. * I:	17.74 in^4	Required I:	47.31 in^4
LL defl. * I:	14.79 in^4	Required I:	78.86 in^4
Actual deflections: TOTAL:	0.19 in		0.16 in

**Force analysis:**

Max. moment:	2278 ft-lb	Max Shear:	1215 lbs
--------------	------------	------------	----------

**Selected Member: (2) HF #2 1.5 x 7.25**

<b>Member properties:</b>	<b>Provided:</b>	<b>Required:</b>
Moment of inertia:	95.27 in^4	78.86 in^4
Section Modulus:	26.28 in^3	23.31 in^3
Section Area:	21.75 in^2	10.57 in^2
Bearing Area:		3. in^2
Minimum bearing dimensions:	3. in x	1. in

Upper Floor, U14: Stair Opening West Flush Beam  
1 piece(s) 5 1/4" x 16" 2.2E Parallam® PSL

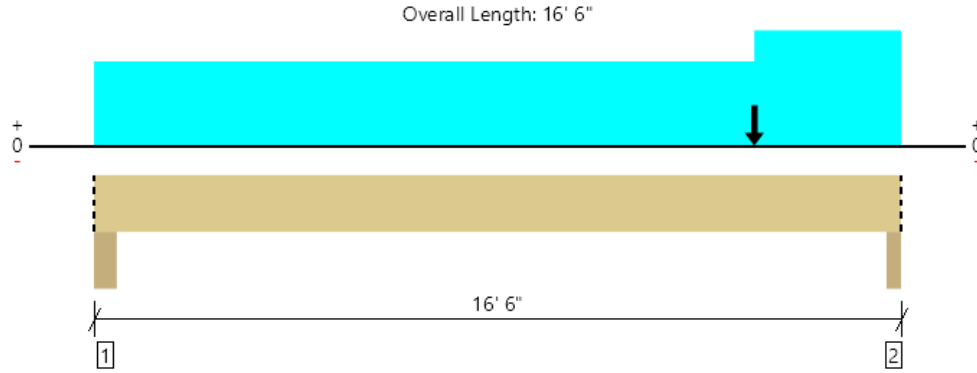

All locations are measured from the outside face of left support (or left cantilever end). All dimensions are horizontal.

Design Results	Actual @ Location	Allowed	Result	LDF	Load: Combination (Pattern)
Member Reaction (lbs)	8409 @ 16' 4"	11484 (3.50")	Passed (73%)	--	1.0 D + 1.0 L (All Spans)
Shear (lbs)	6625 @ 14' 10 1/2"	16240	Passed (41%)	1.00	1.0 D + 1.0 L (All Spans)
Moment (Ft-lbs)	28280 @ 8' 8 1/4"	52432	Passed (54%)	1.00	1.0 D + 1.0 L (All Spans)
Live Load Defl. (in)	0.277 @ 8' 5 1/4"	0.400	Passed (L/694)	--	1.0 D + 1.0 L (All Spans)
Total Load Defl. (in)	0.369 @ 8' 5 1/8"	0.800	Passed (L/520)	--	1.0 D + 1.0 L (All Spans)

System : Floor  
Member Type : Flush Beam  
Building Use : Residential  
Building Code : IBC 2018  
Design Methodology : ASD

- Deflection criteria: LL (L/480) and TL (L/240).
- Allowed moment does not reflect the adjustment for the beam stability factor.

Supports	Bearing Length			Loads to Supports (lbs)			Accessories
	Total	Available	Required	Dead	Floor Live	Factored	
1 - Column - DF	5.50"	5.50"	2.15"	1800	5240	7040	Blocking
2 - Beam - DF	3.50"	3.50"	2.56"	2016	6393	8409	Blocking

- Blocking Panels are assumed to carry no loads applied directly above them and the full load is applied to the member being designed.

Lateral Bracing	Bracing Intervals	Comments
Top Edge (Lu)	16' 6" o/c	
Bottom Edge (Lu)	16' 6" o/c	

- Maximum allowable bracing intervals based on applied load.

Vertical Loads	Location (Side)	Tributary Width	Dead (0.90)	Floor Live (1.00)	Comments
0 - Self Weight (PLF)	0 to 16' 6"	N/A	26.3	--	
1 - Uniform (PSF)	0 to 16' 6" (Front)	10'	12.0	60.0	Deck to the West
2 - Uniform (PSF)	0 to 16' 6" (Front)	8'	8.0	-	Wall
3 - Uniform (PSF)	13' 6" to 16' 6" (Front)	4'	12.0	60.0	Landing
4 - Point (lb)	13' 6" (Front)	N/A	203	1013	

**Weyerhaeuser Notes**

Weyerhaeuser warrants that the sizing of its products will be in accordance with Weyerhaeuser product design criteria and published design values. Weyerhaeuser expressly disclaims any other warranties related to the software. Use of this software is not intended to circumvent the need for a design professional as determined by the authority having jurisdiction. The designer of record, builder or framer is responsible to assure that this calculation is compatible with the overall project. Accessories (Rim Board, Blocking Panels and Squash Blocks) are not designed by this software. Products manufactured at Weyerhaeuser facilities are third-party certified to sustainable forestry standards. Weyerhaeuser Engineered Lumber Products have been evaluated by ICC-ES under evaluation reports ESR-1153 and ESR-1387 and/or tested in accordance with applicable ASTM standards. For current code evaluation reports, Weyerhaeuser product literature and installation details refer to [www.weyerhaeuser.com/woodproducts/document-library](http://www.weyerhaeuser.com/woodproducts/document-library).

The product application, input design loads, dimensions and support information have been provided by ForteWEB Software Operator

ForteWEB Software Operator	Job Notes
William Nocka CSES (978) 503-9935 11wnocka@gmail.com	



John S. Apolis, P.E.

CSES, Inc.

Job number: 2022.136

Project: Li Residence

Date: 13-Oct-22

Designer: Shawn Sullivan

Page number: U15

**Post Design (Combined Axial and Moment Loading)**

2018 International Building Code (IBC)

2018 NDS

**Post Description: Beam U14 North Support**

Snow Load:	1	Wind Load:	
Repetitive Member:		P.T. Lumber:	

Geometry and loads:

Height	11 ft	w(d)	0 plf	M(d)	
Axial Load	7040 lbs	w(b)	0 plf	M(b)	0 ft-lbs
Le(d)	11 ft	Le(b)	0.5 ft		

Material Properties:

Fb1	875 psi	Fb(d)'	1006.3 psi
Fb2	875 psi	Fb(b)'	1006.3 psi
Fc	1350 psi	Fc'	708.67 psi
E	1.6 msi	E'	1.6 msi
Emin	0.58 msi	Emin'	0.58 msi

**Selected Member: DF #2 5.5 x 5.5**

**Member properties:**

Section Modulus (d):	27.7 in^3
Section Modulus (b):	27.7 in^3
Section Area:	30.3 in^2

**Variables:**

Rb(d)	4.90
Rb(b)	1.04
c	0.8

**Member stresses: Provided**

FcE(d)	828 psi	>
FcE(b)	400611 psi	>
FbE	29000 psi	>
FbE	29000 psi	>

**Required**

fc	233 psi	OK
fc	233 psi	OK
fb(d)	0 psi	OK
fb(b)	0 psi	OK

Bending and Axial Compression Check:

NDS 2018 EQ 3.9-3 0.11 < 1.0 **OK**

John S. Apolis, P.E.

CSES, Inc.

Job number: 2022.136

Project: Li Residence

Date: 13-Oct-22

Designer: Shawn Sullivan

Page number: U16

**Post Design (Combined Axial and Moment Loading)**

2018 International Building Code (IBC)

2018 NDS

**Post Description: Beam U14 South Support**

Snow Load:	1	Wind Load:	
Repetitive Member:		P.T. Lumber:	

**Geometry and loads:**

Height	11 ft	w(d)	0 plf	M(d)	
Axial Load	8409 lbs	w(b)	0 plf	M(b)	0 ft-lbs
Le(d)	0.5 ft	Le(b)	11 ft		

**Material Properties:**

Fb1	2400 psi	Fb(d)'	2760 psi
Fb2	2400 psi	Fb(b)'	2760 psi
Fc	2500 psi	Fc'	507.07 psi
E	1.8 msi	E'	1.8 msi
Emin	0.915 msi	Emin'	0.915 msi

**Selected Member: PSL 3.5 x 5.25**

**Member properties:**

Section Modulus (d):	16.1 in^3
Section Modulus (b):	10.7 in^3
Section Area:	18.4 in^2

**Variables:**

Rb(d)	0.87
Rb(b)	7.52
c	0.8

**Member stresses: Provided**

FcE(d)	575850 psi	>
FcE(b)	529 psi	>
FbE	19409 psi	>
FbE	19409 psi	>

**Required**

fc	458 psi	OK
fc	458 psi	OK
fb(d)	0 psi	OK
fb(b)	0 psi	OK

**Bending and Axial Compression Check:**

NDS 2018 EQ 3.9-3 0.81 < 1.0 **OK**

Upper Floor, U17: Roof Deck South East Flush Beam  
1 piece(s) 5 1/4" x 16" 2.2E Parallam® PSL

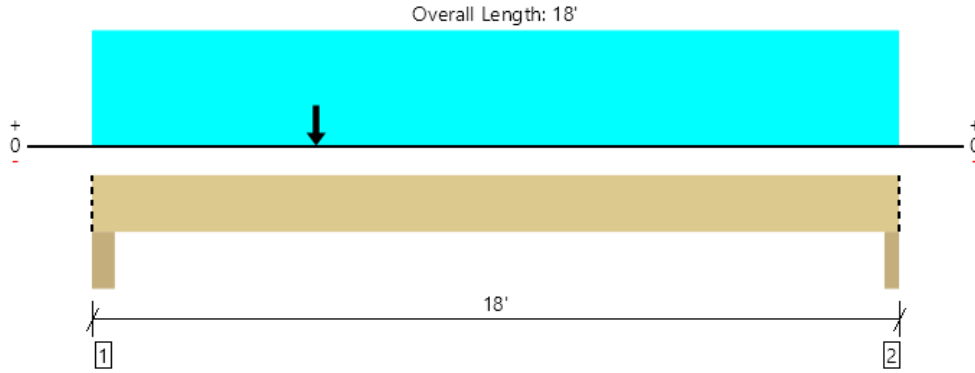

All locations are measured from the outside face of left support (or left cantilever end). All dimensions are horizontal.

Design Results	Actual @ Location	Allowed	Result	LDF	Load: Combination (Pattern)
Member Reaction (lbs)	9383 @ 17' 10"	11484 (3.50")	Passed (82%)	--	1.0 D + 1.0 L (All Spans)
Shear (lbs)	8844 @ 1' 9 1/2"	16240	Passed (54%)	1.00	1.0 D + 1.0 L (All Spans)
Moment (Ft-lbs)	43171 @ 8' 5 5/8"	52432	Passed (82%)	1.00	1.0 D + 1.0 L (All Spans)
Live Load Defl. (in)	0.408 @ 9' 1"	0.438	Passed (L/515)	--	1.0 D + 1.0 L (All Spans)
Total Load Defl. (in)	0.661 @ 8' 11 1/2"	0.875	Passed (L/318)	--	1.0 D + 1.0 L (All Spans)

System : Floor  
Member Type : Flush Beam  
Building Use : Residential  
Building Code : IBC 2018  
Design Methodology : ASD

- Deflection criteria: LL (L/480) and TL (L/240).
- Allowed moment does not reflect the adjustment for the beam stability factor.

Supports	Bearing Length			Loads to Supports (lbs)				Accessories
	Total	Available	Required	Dead	Floor Live	Snow	Factored	
1 - Column - DF	5.50"	5.50"	3.33"	4250	6358	2537	10921	Blocking
2 - Column - DF	3.50"	3.50"	2.86"	3141	6242	923	9383	Blocking

- Blocking Panels are assumed to carry no loads applied directly above them and the full load is applied to the member being designed.

Lateral Bracing	Bracing Intervals	Comments
Top Edge (Lu)	18' o/c	
Bottom Edge (Lu)	18' o/c	

- Maximum allowable bracing intervals based on applied load.

Vertical Loads	Location (Side)	Tributary Width	Dead (0.90)	Floor Live (1.00)	Snow (1.15)	Comments
0 - Self Weight (PLF)	0 to 18'	N/A	26.3	--	--	
1 - Uniform (PSF)	0 to 18' (Front)	5' 6"	12.0	40.0	-	Floor
2 - Uniform (PSF)	0 to 18' (Front)	12'	8.0	-	-	Wall
3 - Point (lb)	5' (Front)	N/A	1231	-	1721	R11, south reaction
4 - Point (lb)	5' (Front)	N/A	1043	-	1739	R13, west reaction
5 - Uniform (PSF)	0 to 18' (Front)	8'	12.0	60.0	-	Roof Deck

**Weyerhaeuser Notes**

Weyerhaeuser warrants that the sizing of its products will be in accordance with Weyerhaeuser product design criteria and published design values. Weyerhaeuser expressly disclaims any other warranties related to the software. Use of this software is not intended to circumvent the need for a design professional as determined by the authority having jurisdiction. The designer of record, builder or framer is responsible to assure that this calculation is compatible with the overall project. Accessories (Rim Board, Blocking Panels and Squash Blocks) are not designed by this software. Products manufactured at Weyerhaeuser facilities are third-party certified to sustainable forestry standards. Weyerhaeuser Engineered Lumber Products have been evaluated by ICC-ES under evaluation reports ESR-1153 and ESR-1387 and/or tested in accordance with applicable ASTM standards. For current code evaluation reports, Weyerhaeuser product literature and installation details refer to [www.weyerhaeuser.com/woodproducts/document-library](http://www.weyerhaeuser.com/woodproducts/document-library).

The product application, input design loads, dimensions and support information have been provided by ForteWEB Software Operator

ForteWEB Software Operator	Job Notes
William Nocka CSES (978) 503-9935 11wnocka@gmail.com	



John S. Apolis, P.E.

CSES, Inc.

Job number: 2022.136

Project: Li Residence

Date: 13-Oct-22

Designer: Shawn Sullivan

Page number: U18

**Post Design (Combined Axial and Moment Loading)**

2018 International Building Code (IBC)

2018 NDS

**Post Description: Beam U17 North Support**

Snow Load:	1	Wind Load:	
Repetitive Member:		P.T. Lumber:	

**Geometry and loads:**

Height	9.5 ft	w(d)	0 plf	M(d)	
Axial Load	9383 lbs	w(b)	0 plf	M(b)	0 ft-lbs
Le(d)	0.5 ft	Le(b)	9.5 ft		

**Material Properties:**

Fb1	2400 psi	Fb(d)'	2760 psi
Fb2	2400 psi	Fb(b)'	2760 psi
Fc	2500 psi	Fc'	668.46 psi
E	1.8 msi	E'	1.8 msi
Emin	0.915 msi	Emin'	0.915 msi

**Selected Member: PSL 3.5 x 5.25**

**Member properties:**

Section Modulus (d):	16.1 in^3
Section Modulus (b):	10.7 in^3
Section Area:	18.4 in^2

**Variables:**

Rb(d)	0.87
Rb(b)	6.99
c	0.8

**Member stresses: Provided**

FcE(d)	575850 psi	>
FcE(b)	709 psi	>
FbE	22474 psi	>
FbE	22474 psi	>

**Required**

fc	511 psi	OK
fc	511 psi	OK
fb(d)	0 psi	OK
fb(b)	0 psi	OK

**Bending and Axial Compression Check:**

NDS 2018 EQ 3.9-3 0.58 < 1.0 **OK**



John S. Apolis, P.E.

CSES, Inc.

Job number: 2022.136

Project: Li Residence

Date: 13-Oct-22

Designer: Shawn Sullivan

Page number: U19

**Post Design (Combined Axial and Moment Loading)**

2018 International Building Code (IBC)

2018 NDS

**Post Description: Beam U17 North Support**

Snow Load:	1	Wind Load:	
Repetitive Member:		P.T. Lumber:	

**Geometry and loads:**

Height	9.5 ft	w(d)	0 plf	M(d)	
Axial Load	10921 lbs	w(b)	0 plf	M(b)	0 ft-lbs
Le(d)	0.5 ft	Le(b)	9.5 ft		

**Material Properties:**

Fb1	875 psi	Fb(d)'	1006.3 psi
Fb2	875 psi	Fb(b)'	1006.3 psi
Fc	1350 psi	Fc'	879.69 psi
E	1.6 msi	E'	1.6 msi
Emin	0.58 msi	Emin'	0.58 msi

**Selected Member: DF #2 5.5 x 5.5**

**Member properties:**

Section Modulus (d):	27.7 in^3
Section Modulus (b):	27.7 in^3
Section Area:	30.3 in^2

**Variables:**

Rb(d)	1.04
Rb(b)	4.55
c	0.8

**Member stresses: Provided**

FcE(d)	400611 psi	>
FcE(b)	1110 psi	>
FbE	33579 psi	>
FbE	33579 psi	>

**Required**

fc	361 psi	OK
fc	361 psi	OK
fb(d)	0 psi	OK
fb(b)	0 psi	OK

**Bending and Axial Compression Check:**

NDS 2018 EQ 3.9-3 0.17 < 1.0 **OK**

John S. Apolis, P.E. CSES, Inc.

Job number: 2022.136

Project: Li Residence

Date: 13-Oct-22

Designer: Shawn Sullivan

Page number: U20

**BEAM DESIGN (Uniform Load+Concentrated Load)**

2018 International Building Code (IBC)

2018 NDS

**Beam Description: Stair Landing Flush Beam**

Fully Supported:	1	Snow Load:	1	Wind Load:	
Repetitive Member:		P.T. Lumber:		Wet Use:	

**Geometry and Loads:**

Span:	11 ft	Tributary Width:	1.33 ft	P Location:	3.75 ft
Add'l uniform DL:	96 lbs/ft	DL unit load:	12 psf	Concentrated DL:	
Add'l uniform LL:		LL unit load:	40 psf	Concentrated LL:	
Add'l uniform SL:		SL unit load:		Concentrated SL:	
Add'l uniform WL:		WL unit load:		Concentrated WL:	

DL Reaction 1:	616 lbs	DL Reaction 2:	616 lbs	Note: Design automatically uses
LL Reaction 1:	293 lbs	LL Reaction 2:	293 lbs	ASD load combinations
SL Reaction 1:	0 lbs	SL Reaction 2:	0 lbs	
WL Reaction 1:	0 lbs	WL Reaction 2:	0 lbs	
Total Reaction 1:	<b>908 lbs</b>	Total Reaction 2:	<b>908 lbs</b>	

**Material Properties:**

E	2 msi	E'	2 msi
Fb	2600 psi	Fb'	3202 psi
Fv	285 psi	Fv'	328 psi
Fc perp	750 psi	Fc perp'	750 psi
Emin	1.016 msi	Emin'	1.016 msi

**Deflection analysis:**

For total load: Allowed deflection criteria, span/	240		
For LL only: Allowed deflection criteria, span/	480		
Max. allowed total defl:	0.55 in	Max LL defl:	0.28 in
Total defl. * I:	27.2 in^4	Required I:	49.46 in^4
LL defl. * I:	8.76 in^4	Required I:	31.86 in^4
Actual deflections:	TOTAL: 0.24 in		0.08 in

**Force analysis:**

Max. moment:	2498 ft-lb	Max Shear:	908 lbs
--------------	------------	------------	---------

**Selected Member: (2) LVL 1.75 x 7.25**

<b>Member properties:</b>	<b>Provided:</b>	<b>Required:</b>
Moment of inertia:	111.15 in^4	49.46 in^4
Section Modulus:	30.66 in^3	9.36 in^3
Section Area:	25.38 in^2	4.16 in^2
Bearing Area:		1.21 in^2
Minimum bearing dimensions:	3.5 in x	0.35 in

Upper Floor, U21: South Flush Beam Below Wall A  
2 piece(s) 1 3/4" x 11 1/4" 2.0E Microllam® LVL

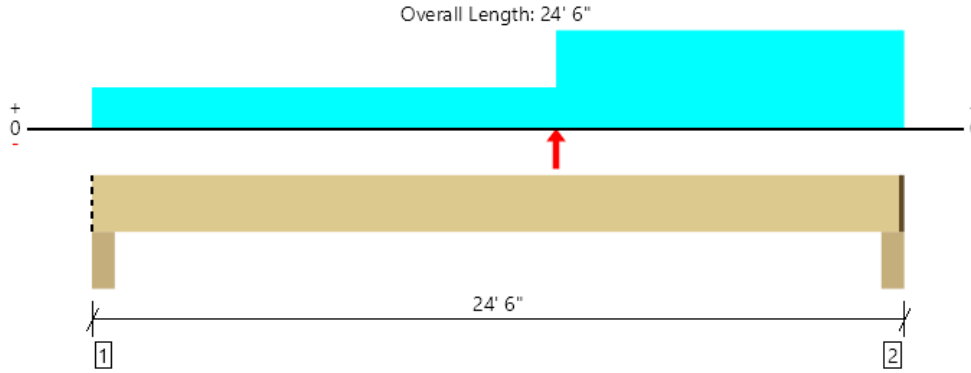

All locations are measured from the outside face of left support (or left cantilever end). All dimensions are horizontal.

Design Results	Actual @ Location	Allowed	Result	LDF	Load: Combination (Pattern)
Member Reaction (lbs)	1750 @ 24' 2"	10784 (4.25")	Passed (16%)	--	1.0 D + 1.0 L (All Spans)
Shear (lbs)	1522 @ 23' 1 1/4"	7481	Passed (20%)	1.00	1.0 D + 1.0 L (All Spans)
Moment (Ft-lbs)	8266 @ 14' 6"	16137	Passed (51%)	1.00	1.0 D + 1.0 L (All Spans)
Live Load Defl. (in)	0.477 @ 12' 3"	0.596	Passed (L/599)	--	1.0 D + 1.0 L (All Spans)
Total Load Defl. (in)	1.032 @ 12' 7 7/16"	1.192	Passed (L/277)	--	1.0 D + 1.0 L (All Spans)

System : Floor  
Member Type : Flush Beam  
Building Use : Residential  
Building Code : IBC 2018  
Design Methodology : ASD

- Deflection criteria: LL (L/480) and TL (L/240).
- Allowed moment does not reflect the adjustment for the beam stability factor.

Supports	Bearing Length			Loads to Supports (lbs)				Accessories
	Total	Available	Required	Dead	Floor Live	Snow	Factored	
1 - Column - HF	5.50"	5.50"	1.50"	529	653	-50	1182	Blocking
2 - Column - HF	5.50"	4.25"	1.50"	1114	653	-68	1767	1 1/4" Rim Board

- Rim Board is assumed to carry all loads applied directly above it, bypassing the member being designed.
- Blocking Panels are assumed to carry no loads applied directly above them and the full load is applied to the member being designed.

Lateral Bracing	Bracing Intervals	Comments
Top Edge (Lu)	16' 11" o/c	
Bottom Edge (Lu)	24' 5" o/c	

- Maximum allowable bracing intervals based on applied load.

Vertical Loads	Location (Side)	Tributary Width	Dead (0.90)	Floor Live (1.00)	Snow (1.15)	Comments
0 - Self Weight (PLF)	0 to 24' 4 3/4"	N/A	11.5	--	--	
1 - Uniform (PSF)	0 to 24' 6" (Front)	1' 4"	12.0	40.0	-	Default Load
2 - Point (lb)	14' (Front)	N/A	-37	-	-118	R8 north reaction
3 - Uniform (PSF)	14' to 24' 6" (Front)	12'	8.0	-	-	

**Weyerhaeuser Notes**

Weyerhaeuser warrants that the sizing of its products will be in accordance with Weyerhaeuser product design criteria and published design values. Weyerhaeuser expressly disclaims any other warranties related to the software. Use of this software is not intended to circumvent the need for a design professional as determined by the authority having jurisdiction. The designer of record, builder or framer is responsible to assure that this calculation is compatible with the overall project. Accessories (Rim Board, Blocking Panels and Squash Blocks) are not designed by this software. Products manufactured at Weyerhaeuser facilities are third-party certified to sustainable forestry standards. Weyerhaeuser Engineered Lumber Products have been evaluated by ICC-ES under evaluation reports ESR-1153 and ESR-1387 and/or tested in accordance with applicable ASTM standards. For current code evaluation reports, Weyerhaeuser product literature and installation details refer to [www.weyerhaeuser.com/woodproducts/document-library](http://www.weyerhaeuser.com/woodproducts/document-library).

The product application, input design loads, dimensions and support information have been provided by ForteWEB Software Operator

ForteWEB Software Operator	Job Notes
William Nocka CSES (978) 503-9935 11wnocka@gmail.com	



Upper Floor, U22: South Flush Beam Below Wall B  
 2 piece(s) 1 3/4" x 14" 2.OE Microllam® LVL

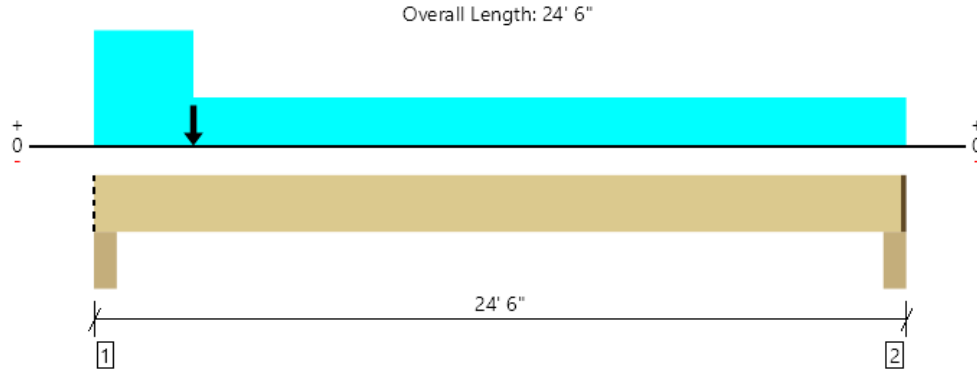

All locations are measured from the outside face of left support (or left cantilever end). All dimensions are horizontal.

Design Results	Actual @ Location	Allowed	Result	LDF	Load: Combination (Pattern)
Member Reaction (lbs)	4464 @ 4"	13956 (5.50")	Passed (32%)	--	1.0 D + 1.0 S (All Spans)
Shear (lbs)	4258 @ 1' 7 1/2"	10707	Passed (40%)	1.15	1.0 D + 1.0 S (All Spans)
Moment (Ft-lbs)	11342 @ 3'	27897	Passed (41%)	1.15	1.0 D + 1.0 S (All Spans)
Live Load Defl. (in)	0.395 @ 11' 4 7/16"	0.596	Passed (L/724)	--	1.0 D + 0.75 L + 0.75 S (All Spans)
Total Load Defl. (in)	0.727 @ 11' 3 15/16"	1.192	Passed (L/393)	--	1.0 D + 0.75 L + 0.75 S (All Spans)

System : Floor  
 Member Type : Flush Beam  
 Building Use : Residential  
 Building Code : IBC 2018  
 Design Methodology : ASD

- Deflection criteria: LL (L/480) and TL (L/240).
- Allowed moment does not reflect the adjustment for the beam stability factor.

Supports	Bearing Length			Loads to Supports (lbs)				Accessories
	Total	Available	Required	Dead	Floor Live	Snow	Factored	
1 - Column - HF	5.50"	5.50"	1.76"	2134	653	2330	4464	Blocking
2 - Column - HF	5.50"	4.25"	1.50"	572	653	293	1282	1 1/4" Rim Board

- Rim Board is assumed to carry all loads applied directly above it, bypassing the member being designed.
- Blocking Panels are assumed to carry no loads applied directly above them and the full load is applied to the member being designed.

Lateral Bracing	Bracing Intervals	Comments
Top Edge (Lu)	15' 1" o/c	
Bottom Edge (Lu)	24' 5" o/c	

- Maximum allowable bracing intervals based on applied load.

Vertical Loads	Location (Side)	Tributary Width	Dead (0.90)	Floor Live (1.00)	Snow (1.15)	Comments
0 - Self Weight (PLF)	0 to 24' 4 3/4"	N/A	14.3	--	--	
1 - Uniform (PSF)	0 to 24' 6" (Front)	1' 4"	12.0	40.0	-	Default Load
2 - Point (lb)	3' (Front)	N/A	634	-	884	R12 south reaction
3 - Uniform (PSF)	0 to 3' (Front)	12'	8.0	-	-	
4 - Point (lb)	3' (Front)	N/A	1043	-	1739	R13 east reaction

**Weyerhaeuser Notes**

Weyerhaeuser warrants that the sizing of its products will be in accordance with Weyerhaeuser product design criteria and published design values. Weyerhaeuser expressly disclaims any other warranties related to the software. Use of this software is not intended to circumvent the need for a design professional as determined by the authority having jurisdiction. The designer of record, builder or framer is responsible to assure that this calculation is compatible with the overall project. Accessories (Rim Board, Blocking Panels and Squash Blocks) are not designed by this software. Products manufactured at Weyerhaeuser facilities are third-party certified to sustainable forestry standards. Weyerhaeuser Engineered Lumber Products have been evaluated by ICC-ES under evaluation reports ESR-1153 and ESR-1387 and/or tested in accordance with applicable ASTM standards. For current code evaluation reports, Weyerhaeuser product literature and installation details refer to [www.weyerhaeuser.com/woodproducts/document-library](http://www.weyerhaeuser.com/woodproducts/document-library).

The product application, input design loads, dimensions and support information have been provided by ForteWEB Software Operator

ForteWEB Software Operator	Job Notes
William Nocka CSES (978) 503-9935 11wnocka@gmail.com	



Upper Floor, U23.0: South Flush Beam Below Wall C  
2 piece(s) 1 3/4" x 14" 2.OE Microllam® LVL

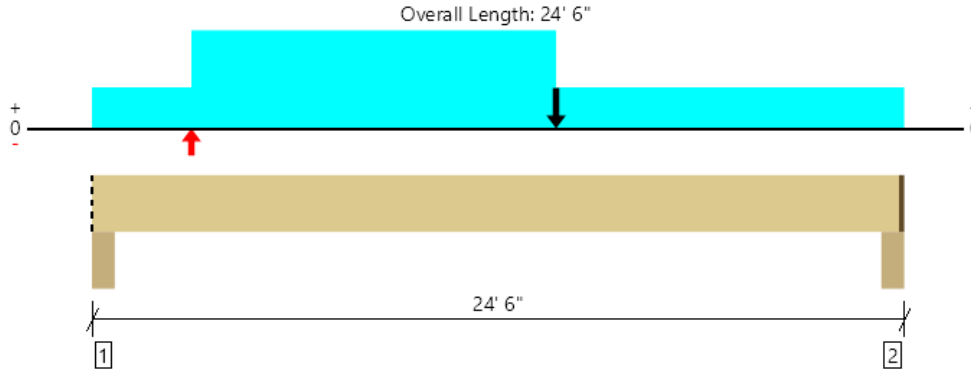

All locations are measured from the outside face of left support (or left cantilever end). All dimensions are horizontal.

Design Results	Actual @ Location	Allowed	Result	LDF	Load: Combination (Pattern)
Member Reaction (lbs)	1965 @ 24' 2"	10784 (4.25")	Passed (18%)	--	1.0 D + 0.525 E + 0.75 L + 0.75 S (All Spans)
Shear (lbs)	1718 @ 1' 7 1/2"	9310	Passed (18%)	1.00	1.0 D + 1.0 L (All Spans)
Moment (Ft-lbs)	11724 @ 11' 11 1/16"	24258	Passed (48%)	1.00	1.0 D + 1.0 L (All Spans)
Live Load Defl. (in)	0.461 @ 12' 10 1/2"	0.596	Passed (L/620)	--	1.0 D + 0.525 E + 0.75 L + 0.75 S (All Spans)
Total Load Defl. (in)	0.964 @ 12' 5 5/16"	1.192	Passed (L/297)	--	1.0 D + 0.525 E + 0.75 L + 0.75 S (All Spans)

System : Floor  
Member Type : Flush Beam  
Building Use : Residential  
Building Code : IBC 2018  
Design Methodology : ASD

- Deflection criteria: LL (L/480) and TL (L/240).
- Allowed moment does not reflect the adjustment for the beam stability factor.

Supports	Bearing Length			Loads to Supports (lbs)					Accessories
	Total	Available	Required	Dead	Floor Live	Snow	Seismic	Factored	
1 - Column - HF	5.50"	5.50"	1.50"	1200	653	212	675/-675	2204	Blocking
2 - Column - HF	5.50"	4.25"	1.50"	913	653	285	675/-675	1971	1 1/4" Rim Board

- Rim Board is assumed to carry all loads applied directly above it, bypassing the member being designed.
- Blocking Panels are assumed to carry no loads applied directly above them and the full load is applied to the member being designed.

Lateral Bracing	Bracing Intervals	Comments
Top Edge (Lu)	9' 11" o/c	
Bottom Edge (Lu)	24' 5" o/c	

- Maximum allowable bracing intervals based on applied load.

Vertical Loads	Location (Side)	Tributary Width	Dead (0.90)	Floor Live (1.00)	Snow (1.15)	Seismic (1.60)	Comments
0 - Self Weight (PLF)	0 to 24' 4 3/4"	N/A	14.3	--	--	--	
1 - Uniform (PSF)	0 to 24' 6" (Front)	1' 4"	12.0	40.0	-	-	Default Load
2 - Point (lb)	3' (Front)	N/A	-	-	-	-1462	SW Hold down
3 - Uniform (PSF)	3' to 14' (Front)	12'	8.0	-	-	-	
4 - Point (lb)	14' (Front)	N/A	-	-	-	1462	SW hold down
5 - Point (lb)	14' (Front)	N/A	317	-	497	-	R8 south reaction

**Weyerhaeuser Notes**

Weyerhaeuser warrants that the sizing of its products will be in accordance with Weyerhaeuser product design criteria and published design values. Weyerhaeuser expressly disclaims any other warranties related to the software. Use of this software is not intended to circumvent the need for a design professional as determined by the authority having jurisdiction. The designer of record, builder or framer is responsible to assure that this calculation is compatible with the overall project. Accessories (Rim Board, Blocking Panels and Squash Blocks) are not designed by this software. Products manufactured at Weyerhaeuser facilities are third-party certified to sustainable forestry standards. Weyerhaeuser Engineered Lumber Products have been evaluated by ICC-ES under evaluation reports ESR-1153 and ESR-1387 and/or tested in accordance with applicable ASTM standards. For current code evaluation reports, Weyerhaeuser product literature and installation details refer to [www.weyerhaeuser.com/woodproducts/document-library](http://www.weyerhaeuser.com/woodproducts/document-library).

The product application, input design loads, dimensions and support information have been provided by ForteWEB Software Operator

ForteWEB Software Operator	Job Notes
William Nocka CSES (978) 503-9935 11wnocka@gmail.com	



Upper Floor, U23.1: South Flush Beam Below Wall C - Seismic Overstrength  
2 piece(s) 1 3/4" x 16" 2.OE Microllam® LVL

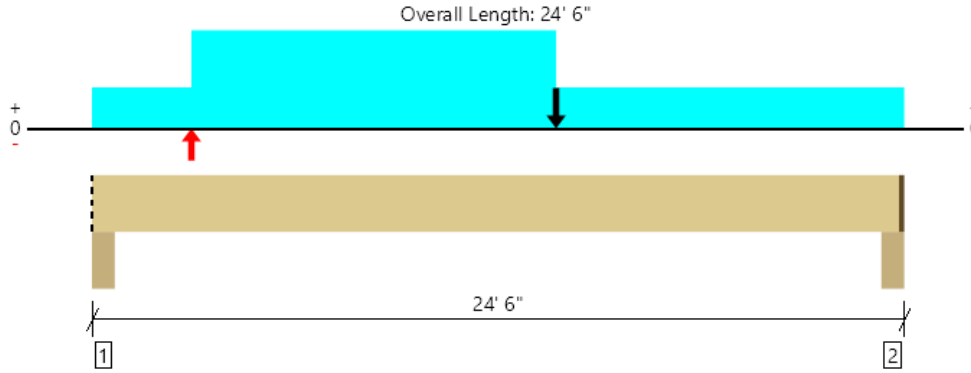

All locations are measured from the outside face of left support (or left cantilever end). All dimensions are horizontal.

Design Results	Actual @ Location	Allowed	Result	LDF	Load: Combination (Pattern)
Member Reaction (lbs)	2522 @ 24' 2"	10784 (4.25")	Passed (23%)	--	1.0 D + 0.525 E + 0.75 L + 0.75 S (All Spans)
Shear (lbs)	1725 @ 1' 9 1/2"	10640	Passed (16%)	1.00	1.0 D + 1.0 L (All Spans)
Moment (Ft-lbs)	21729 @ 14'	49783	Passed (44%)	1.60	1.0 D + 0.525 E + 0.75 L + 0.75 S (All Spans)
Live Load Defl. (in)	0.476 @ 13' 1 1/4"	0.596	Passed (L/601)	--	1.0 D + 0.525 E + 0.75 L + 0.75 S (All Spans)
Total Load Defl. (in)	0.821 @ 12' 8 1/4"	1.192	Passed (L/348)	--	1.0 D + 0.525 E + 0.75 L + 0.75 S (All Spans)

System : Floor  
Member Type : Flush Beam  
Building Use : Residential  
Building Code : IBC 2018  
Design Methodology : ASD

- Deflection criteria: LL (L/480) and TL (L/240).
- Allowed moment does not reflect the adjustment for the beam stability factor.
- -446 lbs uplift at support located at 4". Strapping or other restraint may be required.
- -618 lbs uplift at support located at 24' 2". Strapping or other restraint may be required.

Supports	Bearing Length			Loads to Supports (lbs)					Accessories
	Total	Available	Required	Dead	Floor Live	Snow	Seismic	Factored	
1 - Column - HF	5.50"	5.50"	1.50"	1225	653	212	1687/-1687	2760/-446	Blocking
2 - Column - HF	5.50"	4.25"	1.50"	938	653	285	1687/-1687	2527/-618	1 1/4" Rim Board

- Rim Board is assumed to carry all loads applied directly above it, bypassing the member being designed.
- Blocking Panels are assumed to carry no loads applied directly above them and the full load is applied to the member being designed.

Lateral Bracing	Bracing Intervals	Comments
Top Edge (Lu)	7' 11" o/c	
Bottom Edge (Lu)	24' 5" o/c	

- Maximum allowable bracing intervals based on applied load.

Vertical Loads	Location (Side)	Tributary Width	Dead (0.90)	Floor Live (1.00)	Snow (1.15)	Seismic (1.60)	Comments
0 - Self Weight (PLF)	0 to 24' 4 3/4"	N/A	16.3	--	--	--	
1 - Uniform (PSF)	0 to 24' 6" (Front)	1' 4"	12.0	40.0	-	-	Default Load
2 - Point (lb)	3' (Front)	N/A	-	-	-	-3655	SW Hold down
3 - Uniform (PSF)	3' to 14' (Front)	12'	8.0	-	-	-	
4 - Point (lb)	14' (Front)	N/A	-	-	-	3655	SW hold down
5 - Point (lb)	14' (Front)	N/A	317	-	497	-	R8 south reaction

**Weyerhaeuser Notes**

Weyerhaeuser warrants that the sizing of its products will be in accordance with Weyerhaeuser product design criteria and published design values. Weyerhaeuser expressly disclaims any other warranties related to the software. Use of this software is not intended to circumvent the need for a design professional as determined by the authority having jurisdiction. The designer of record, builder or framer is responsible to assure that this calculation is compatible with the overall project. Accessories (Rim Board, Blocking Panels and Squash Blocks) are not designed by this software. Products manufactured at Weyerhaeuser facilities are third-party certified to sustainable forestry standards. Weyerhaeuser Engineered Lumber Products have been evaluated by ICC-ES under evaluation reports ESR-1153 and ESR-1387 and/or tested in accordance with applicable ASTM standards. For current code evaluation reports, Weyerhaeuser product literature and installation details refer to [www.eyerhaeuser.com/woodproducts/document-library](http://www.eyerhaeuser.com/woodproducts/document-library).

The product application, input design loads, dimensions and support information have been provided by ForteWEB Software Operator

ForteWEB Software Operator	Job Notes
William Nocka CSES (978) 503-9935 11wnocka@gmail.com	



John S. Apolis, P.E. CSES, Inc.

Job number: 2022.136

Project: Li Residence

Date: 13-Oct-22

Designer: Shawn Sullivan

Page number: U24

**BEAM DESIGN (Uniform Load+Concentrated Load)**

2018 International Building Code (IBC)

2018 NDS

**Beam Description: East Header**

Fully Supported:	1	Snow Load:		Wind Load:	
Repetitive Member:		P.T. Lumber:		Wet Use:	

**Geometry and Loads:**

Span:	12.75 ft	Tributary Width:	12 ft	P Location:	3.75 ft
Add'l uniform DL:	96 lbs/ft	DL unit load:	12 psf	Concentrated DL:	
Add'l uniform LL:		LL unit load:	40 psf	Concentrated LL:	
Add'l uniform SL:		SL unit load:		Concentrated SL:	
Add'l uniform WL:		WL unit load:		Concentrated WL:	

DL Reaction 1:	1530 lbs	DL Reaction 2:	1530 lbs	Note: Design automatically uses
LL Reaction 1:	3060 lbs	LL Reaction 2:	3060 lbs	ASD load combinations
SL Reaction 1:	0 lbs	SL Reaction 2:	0 lbs	
WL Reaction 1:	0 lbs	WL Reaction 2:	0 lbs	
Total Reaction 1:	<b>4590 lbs</b>	Total Reaction 2:	<b>4590 lbs</b>	

**Material Properties:**

E	2 msi	E'	2 msi
Fb	2600 psi	Fb'	2604 psi
Fv	285 psi	Fv'	285 psi
Fc perp	750 psi	Fc perp'	750 psi
Emin	1.016 msi	Emin'	1.016 msi

**Deflection analysis:**

For total load: Allowed deflection criteria, span/	240		
For LL only: Allowed deflection criteria, span/	480		
Max. allowed total defl:	0.64 in	Max LL defl:	0.32 in
Total defl. * I:	214.06 in^4	Required I:	335.77 in^4
LL defl. * I:	142.7 in^4	Required I:	447.7 in^4
Actual deflections: TOTAL:	0.44 in		0.29 in

**Force analysis:**

Max. moment:	14631 ft-lb	Max Shear:	4590 lbs
--------------	-------------	------------	----------

**Selected Member: (2) LVL 1.75 x 11.875**

<b>Member properties:</b>	<b>Provided:</b>	<b>Required:</b>
Moment of inertia:	488.41 in^4	447.7 in^4
Section Modulus:	82.26 in^3	67.43 in^3
Section Area:	41.56 in^2	24.16 in^2
Bearing Area:		6.12 in^2
Minimum bearing dimensions:	3.5 in x	1.75 in

John S. Apolis, P.E.

CSES, Inc.

Job number: 2022.136

Project: Li Residence

Date: 13-Oct-22

Designer: Shawn Sullivan

Page number: U25

**Post Design (Combined Axial and Moment Loading)**

2018 International Building Code (IBC)

2018 NDS

**Post Description: Beam U24 South Support**

Snow Load:	1	Wind Load:	
Repetitive Member:		P.T. Lumber:	

**Geometry and loads:**

Height	9.5 ft	w(d)	0 plf	M(d)	
Axial Load	9677 lbs	w(b)	0 plf	M(b)	0 ft-lbs
Le(d)	0.5 ft	Le(b)	9.5 ft		

**Material Properties:**

Fb1	875 psi	Fb(d)'	1006.3 psi
Fb2	875 psi	Fb(b)'	1006.3 psi
Fc	1350 psi	Fc'	879.69 psi
E	1.6 msi	E'	1.6 msi
Emin	0.58 msi	Emin'	0.58 msi

**Selected Member: DF #2 5.5 x 5.5**

**Member properties:**

Section Modulus (d):	27.7 in^3
Section Modulus (b):	27.7 in^3
Section Area:	30.3 in^2

**Variables:**

Rb(d)	1.04
Rb(b)	4.55
c	0.8

**Member stresses: Provided**

FcE(d)	400611 psi	>
FcE(b)	1110 psi	>
FbE	33579 psi	>
FbE	33579 psi	>

**Required**

fc	320 psi	OK
fc	320 psi	OK
fb(d)	0 psi	OK
fb(b)	0 psi	OK

**Bending and Axial Compression Check:**

NDS 2018 EQ 3.9-3 0.13 < 1.0 **OK**



Upper Floor, U26: West Roof Joist  
1 piece(s) 2 x 12 HF No.2 @ 24" OC

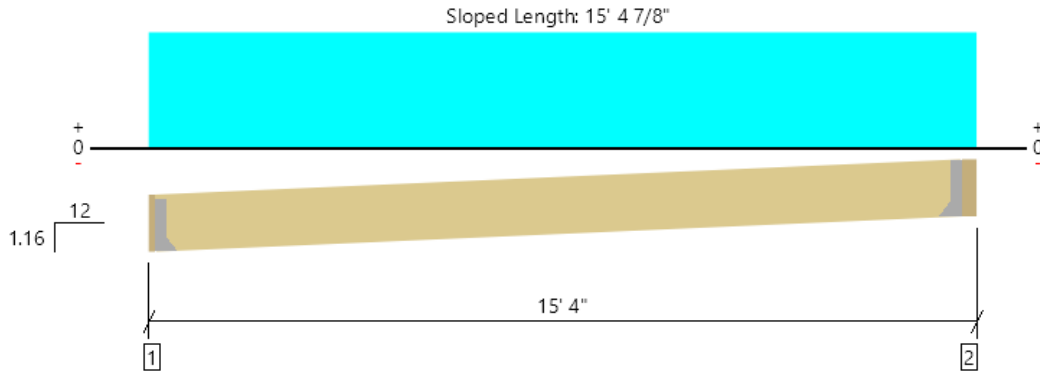

All locations are measured from the outside face of left support (or left cantilever end). All dimensions are horizontal.

Member Length : 15' 15/16"

Design Results	Actual @ Location	Allowed	Result	LDF	Load: Combination (Pattern)
Member Reaction (lbs)	598 @ 1' 1/2"	911 (1.50")	Passed (66%)	--	1.0 D + 1.0 S (All Spans)
Shear (lbs)	523 @ 1' 11/16"	1941	Passed (27%)	1.15	1.0 D + 1.0 S (All Spans)
Moment (Ft-lbs)	2229 @ 7' 7"	2964	Passed (75%)	1.15	1.0 D + 1.0 S (All Spans)
Live Load Defl. (in)	0.243 @ 7' 7"	0.749	Passed (L/740)	--	1.0 D + 1.0 S (All Spans)
Total Load Defl. (in)	0.389 @ 7' 7"	0.999	Passed (L/462)	--	1.0 D + 1.0 S (All Spans)

System : Roof  
Member Type : Joist  
Building Use : Residential  
Building Code : IBC 2018  
Design Methodology : ASD  
Member Pitch : 1.16/12

- Deflection criteria: LL (L/240) and TL (L/180).
- Allowed moment does not reflect the adjustment for the beam stability factor.
- A 15% increase in the moment capacity has been added to account for repetitive member usage.
- Applicable calculations are based on NDS.

Supports	Bearing Length			Loads to Supports (lbs)			Accessories
	Total	Available	Required	Dead	Snow	Factored	
1 - Hanger on 11 1/4" DF ledger On Masonry	1.50"	Hanger <sup>1</sup>	1.50"	229	379	608	See note <sup>1</sup>
2 - Hanger on 11 1/4" PSL beam	3.50"	Hanger <sup>1</sup>	1.50"	234	388	621	See note <sup>1</sup>

- At hanger supports, the Total Bearing dimension is equal to the width of the material that is supporting the hanger
- <sup>1</sup> See Connector grid below for additional information and/or requirements.

Lateral Bracing	Bracing Intervals	Comments
Top Edge (Lu)	4' 8" o/c	
Bottom Edge (Lu)	15' o/c	

- Maximum allowable bracing intervals based on applied load.

Connector: Simpson Strong-Tie							
Support	Model	Seat Length	Top Fasteners	Face Fasteners	Member Fasteners	Accessories	
1 - Face Mount Hanger	LRU28Z	1.94"	N/A	6-10dx1.5	5-10d		
2 - Face Mount Hanger	LRU28Z	1.94"	N/A	6-10dx1.5	5-10d		

- Refer to manufacturer notes and instructions for proper installation and use of all connectors.

Vertical Load	Location (Side)	Spacing	Dead (0.90)	Snow (1.15)	Comments
1 - Uniform (PSF)	0 to 15' 4"	24"	15.0	25.0	Default Load

**Weyerhaeuser Notes**

Weyerhaeuser warrants that the sizing of its products will be in accordance with Weyerhaeuser product design criteria and published design values. Weyerhaeuser expressly disclaims any other warranties related to the software. Use of this software is not intended to circumvent the need for a design professional as determined by the authority having jurisdiction. The designer of record, builder or framer is responsible to assure that this calculation is compatible with the overall project. Accessories (Rim Board, Blocking Panels and Squash Blocks) are not designed by this software. Products manufactured at Weyerhaeuser facilities are third-party certified to sustainable forestry standards. Weyerhaeuser Engineered Lumber Products have been evaluated by ICC-ES under evaluation reports ESR-1153 and ESR-1387 and/or tested in accordance with applicable ASTM standards. For current code evaluation reports, Weyerhaeuser product literature and installation details refer to [www.woyehaeuser.com/woodproducts/document-library](http://www.woyehaeuser.com/woodproducts/document-library).

The product application, input design loads, dimensions and support information have been provided by ForteWEB Software Operator

ForteWEB Software Operator	Job Notes
William Nocka CSES (978) 503-9935 11wnocka@gmail.com	



Upper Floor, U27: West Roof Joist, Cantilevered  
1 piece(s) 2 x 12 HF No.2 @ 24" OC

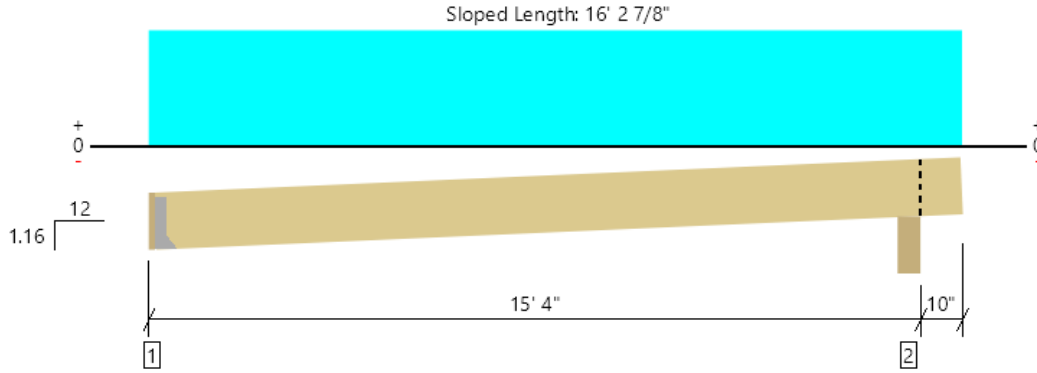

All locations are measured from the outside face of left support (or left cantilever end). All dimensions are horizontal.

Member Length : 16' 2 1/2"

Design Results	Actual @ Location	Allowed	Result	LDF	Load: Combination (Pattern)
Member Reaction (lbs)	598 @ 1 1/2"	911 (1.50")	Passed (66%)	--	1.0 D + 1.0 S (Alt Spans)
Shear (lbs)	523 @ 1' 11/16"	1941	Passed (27%)	1.15	1.0 D + 1.0 S (Alt Spans)
Moment (Ft-lbs)	2232 @ 7' 7 1/16"	2964	Passed (75%)	1.15	1.0 D + 1.0 S (Alt Spans)
Live Load Defl. (in)	0.246 @ 7' 7 5/16"	0.752	Passed (L/735)	--	1.0 D + 1.0 S (Alt Spans)
Total Load Defl. (in)	0.393 @ 7' 7 1/4"	1.003	Passed (L/460)	--	1.0 D + 1.0 S (Alt Spans)

System : Roof  
Member Type : Joist  
Building Use : Residential  
Building Code : IBC 2018  
Design Methodology : ASD  
Member Pitch : 1.16/12

- Deflection criteria: LL (L/240) and TL (L/180).
- Overhang deflection criteria: LL (2L/240) and TL (2L/180).
- Allowed moment does not reflect the adjustment for the beam stability factor.
- A 15% increase in the moment capacity has been added to account for repetitive member usage.
- Applicable calculations are based on NDS.

Supports	Bearing Length			Loads to Supports (lbs)			Accessories
	Total	Available	Required	Dead	Snow	Factored	
1 - Hanger on 1 1/4" DF ledger On Masonry	1.50"	Hanger <sup>1</sup>	1.50"	228	380	608	See note <sup>1</sup>
2 - Beveled Plate - HF	5.50"	5.50"	1.50"	259	429	688	Blocking

- Blocking Panels are assumed to carry no loads applied directly above them and the full load is applied to the member being designed.
- At hanger supports, the Total Bearing dimension is equal to the width of the material that is supporting the hanger
- <sup>1</sup> See Connector grid below for additional information and/or requirements.

Lateral Bracing	Bracing Intervals	Comments
Top Edge (Lu)	4' 8" o/c	
Bottom Edge (Lu)	16' 1" o/c	

•Maximum allowable bracing intervals based on applied load.

Connector: Simpson Strong-Tie							
Support	Model	Seat Length	Top Fasteners	Face Fasteners	Member Fasteners	Accessories	
1 - Face Mount Hanger	LRU28Z	1.94"	N/A	6-10dx1.5	5-10d		

- Refer to manufacturer notes and instructions for proper installation and use of all connectors.

Vertical Load	Location (Side)	Spacing	Dead (0.90)	Snow (1.15)	Comments
1 - Uniform (PSF)	0 to 16' 2"	24"	15.0	25.0	Default Load

**Weyerhaeuser Notes**

Weyerhaeuser warrants that the sizing of its products will be in accordance with Weyerhaeuser product design criteria and published design values. Weyerhaeuser expressly disclaims any other warranties related to the software. Use of this software is not intended to circumvent the need for a design professional as determined by the authority having jurisdiction. The designer of record, builder or framer is responsible to assure that this calculation is compatible with the overall project. Accessories (Rim Board, Blocking Panels and Squash Blocks) are not designed by this software. Products manufactured at Weyerhaeuser facilities are third-party certified to sustainable forestry standards. Weyerhaeuser Engineered Lumber Products have been evaluated by ICC-ES under evaluation reports ESR-1153 and ESR-1387 and/or tested in accordance with applicable ASTM standards. For current code evaluation reports, Weyerhaeuser product literature and installation details refer to [www.weyerhaeuser.com/woodproducts/document-library](http://www.weyerhaeuser.com/woodproducts/document-library).

The product application, input design loads, dimensions and support information have been provided by ForteWEB Software Operator

ForteWEB Software Operator	Job Notes
William Nocka CSES (978) 503-9935 11wnocka@gmail.com	



John S. Apolis, P.E. CSES, Inc.

Job number: 2022.136

Project: Li Residence

Date: 13-Oct-22

Designer: Shawn Sullivan

Page number: U28

**BEAM DESIGN (Uniform Load+Concentrated Load)**

2018 International Building Code (IBC)

2018 NDS

**Beam Description: West Patio Roof Flush Beam**

Fully Supported:	1	Snow Load:	1	Wind Load:	
Repetitive Member:		P.T. Lumber:		Wet Use:	

**Geometry and Loads:**

Span:	21 ft	Tributary Width:	8 ft	P Location:	3.75 ft
Add'l uniform DL:		DL unit load:	15 psf	Concentrated DL:	
Add'l uniform LL:		LL unit load:		Concentrated LL:	
Add'l uniform SL:		SL unit load:	25 psf	Concentrated SL:	
Add'l uniform WL:		WL unit load:		Concentrated WL:	

DL Reaction 1:	1260 lbs	DL Reaction 2:	1260 lbs	Note: Design automatically uses
LL Reaction 1:	0 lbs	LL Reaction 2:	0 lbs	ASD load combinations
SL Reaction 1:	2100 lbs	SL Reaction 2:	2100 lbs	
WL Reaction 1:	0 lbs	WL Reaction 2:	0 lbs	
Total Reaction 1:	<b>3360 lbs</b>	Total Reaction 2:	<b>3360 lbs</b>	

**Material Properties:**

E	2.2 msi	E'	2.2 msi
Fb	2900 psi	Fb'	3359 psi
Fv	290 psi	Fv'	334 psi
Fc perp	625 psi	Fc perp'	625 psi
Emin	0.914 msi	Emin'	0.914 msi

**Deflection analysis:**

For total load: Allowed deflection criteria, span/	240		
For LL only: Allowed deflection criteria, span/	360		
Max. allowed total defl:	1.05 in	Max LL defl:	0.7 in
Total defl. * I:	636.48 in^4	Required I:	606.17 in^4
LL defl. * I:	397.8 in^4	Required I:	568.29 in^4
Actual deflections: TOTAL:	1.02 in		0.64 in

**Force analysis:**

Max. moment:	17640 ft-lb	Max Shear:	3360 lbs
--------------	-------------	------------	----------

**Selected Member: (1) PSL 5.25 x 11.25**

<b>Member properties:</b>	<b>Provided:</b>	<b>Required:</b>
Moment of inertia:	622.92 in^4	606.17 in^4
Section Modulus:	110.74 in^3	63.02 in^3
Section Area:	59.06 in^2	15.11 in^2
Bearing Area:		5.38 in^2
Minimum bearing dimensions:	5.25 in x	1.02 in

John S. Apolis, P.E.

CSES, Inc.

Job number: 2022.136

Project: Li Residence

Date: 13-Oct-22

Designer: Shawn Sullivan

Page number: U29

**Post Design (Combined Axial and Moment Loading)**

2018 International Building Code (IBC)

2018 NDS

**Post Description: Beam U28 South Support**

Snow Load:	1	Wind Load:	
Repetitive Member:		P.T. Lumber:	

**Geometry and loads:**

Height	11 ft	w(d)	0 plf	M(d)	
Axial Load	3360 lbs	w(b)	0 plf	M(b)	0 ft-lbs
Le(d)	11 ft	Le(b)	8 ft		

**Material Properties:**

Fb1	850 psi	Fb(d)'	977.5 psi
Fb2	850 psi	Fb(b)'	977.5 psi
Fc	1300 psi	Fc'	355.15 psi
E	1.3 msi	E'	1.3 msi
Emin	0.47 msi	Emin'	0.47 msi

**Selected Member: HF #2 3 x 5.5**

**Member properties:**

Section Modulus (d):	15.1 in^3
Section Modulus (b):	8.3 in^3
Section Area:	16.5 in^2

**Variables:**

Rb(d)	3.62
Rb(b)	7.66
c	0.8

**Member stresses: Provided**

FcE(d)	671 psi	>
FcE(b)	377 psi	>
FbE	9614 psi	>
FbE	9614 psi	>

**Required**

fc	204 psi	OK
fc	204 psi	OK
fb(d)	0 psi	OK
fb(b)	0 psi	OK

**Bending and Axial Compression Check:**

NDS 2018 EQ 3.9-3 0.33 < 1.0 **OK**

John S. Apolis, P.E. CSES, Inc.

Job number: 2022.136

Project: Li Residence

Date: 13-Oct-22

Designer: Shawn Sullivan

Page number: U30

**BEAM DESIGN (Uniform Load+Concentrated Load)**

2018 International Building Code (IBC)

2018 NDS

**Beam Description: Grid C Header 1**

Fully Supported:	1	Snow Load:	1	Wind Load:	
Repetitive Member:		P.T. Lumber:		Wet Use:	

**Geometry and Loads:**

Span:	4.75 ft	Tributary Width:	10 ft	P Location:	3.75 ft
Add'l uniform DL:	120 lbs/ft	DL unit load:	12 psf	Concentrated DL:	
Add'l uniform LL:		LL unit load:	60 psf	Concentrated LL:	
Add'l uniform SL:	200 lbs/ft	SL unit load:	25 psf	Concentrated SL:	
Add'l uniform WL:		WL unit load:		Concentrated WL:	

DL Reaction 1:	570 lbs	DL Reaction 2:	570 lbs	Note: Design automatically uses
LL Reaction 1:	1425 lbs	LL Reaction 2:	1425 lbs	ASD load combinations
SL Reaction 1:	1069 lbs	SL Reaction 2:	1069 lbs	
WL Reaction 1:	0 lbs	WL Reaction 2:	0 lbs	
Total Reaction 1:	<b>2440 lbs</b>	Total Reaction 2:	<b>2440 lbs</b>	

**Material Properties:**

E	1.3 msi	E'	1.3 msi
Fb	850 psi	Fb'	1075 psi
Fv	150 psi	Fv'	173 psi
Fc perp	405 psi	Fc perp'	405 psi
Emin	0.47 msi	Emin'	0.47 msi

**Deflection analysis:**

For total load: Allowed deflection criteria, span/	240		
For LL only: Allowed deflection criteria, span/	360		
Max. allowed total defl:	0.24 in	Max LL defl:	0.16 in
Total defl. * I:	11.37 in^4	Required I:	47.86 in^4
LL defl. * I:	9.25 in^4	Required I:	58.43 in^4
Actual deflections:	TOTAL: 0.06 in		0.05 in

**Force analysis:**

Max. moment:	2898 ft-lb	Max Shear:	2440 lbs
--------------	------------	------------	----------

**Selected Member: (2) HF #2 1.5 x 9.25**

<b>Member properties:</b>	<b>Provided:</b>	<b>Required:</b>
Moment of inertia:	197.86 in^4	58.43 in^4
Section Modulus:	42.78 in^3	32.34 in^3
Section Area:	27.75 in^2	21.22 in^2
Bearing Area:		6.03 in^2
Minimum bearing dimensions:	3. in x	2.01 in

John S. Apolis, P.E. CSES, Inc.

Job number: 2022.136

Project: Li Residence

Date: 13-Oct-22

Designer: Shawn Sullivan

Page number: U31

**BEAM DESIGN (Uniform Load+Concentrated Load)**

2018 International Building Code (IBC)

2018 NDS

**Beam Description: Grid C Header 2**

Fully Supported:	1	Snow Load:	1	Wind Load:	
Repetitive Member:		P.T. Lumber:		Wet Use:	

**Geometry and Loads:**

Span:	8.25 ft	Tributary Width:	10 ft	P Location:	3.75 ft
Add'l uniform DL:	120 lbs/ft	DL unit load:	12 psf	Concentrated DL:	
Add'l uniform LL:		LL unit load:	60 psf	Concentrated LL:	
Add'l uniform SL:	200 lbs/ft	SL unit load:	25 psf	Concentrated SL:	
Add'l uniform WL:		WL unit load:		Concentrated WL:	

DL Reaction 1:	990 lbs	DL Reaction 2:	990 lbs	Note: Design automatically uses
LL Reaction 1:	2475 lbs	LL Reaction 2:	2475 lbs	ASD load combinations
SL Reaction 1:	1856 lbs	SL Reaction 2:	1856 lbs	
WL Reaction 1:	0 lbs	WL Reaction 2:	0 lbs	
Total Reaction 1:	<b>4238 lbs</b>	Total Reaction 2:	<b>4238 lbs</b>	

**Material Properties:**

E	2 msi	E'	2 msi
Fb	2600 psi	Fb'	3098 psi
Fv	285 psi	Fv'	328 psi
Fc perp	750 psi	Fc perp'	750 psi
Emin	1.016 msi	Emin'	1.016 msi

**Deflection analysis:**

For total load: Allowed deflection criteria, span/	240		
For LL only: Allowed deflection criteria, span/	360		
Max. allowed total defl:	0.41 in	Max LL defl:	0.28 in
Total defl. * I:	67.23 in^4	Required I:	162.98 in^4
LL defl. * I:	54.72 in^4	Required I:	198.99 in^4
Actual deflections:	TOTAL: 0.29 in		0.24 in

**Force analysis:**

Max. moment:	8742 ft-lb	Max Shear:	4238 lbs
--------------	------------	------------	----------

**Selected Member: (2) LVL 1.75 x 9.25**

<b>Member properties:</b>	<b>Provided:</b>	<b>Required:</b>
Moment of inertia:	230.84 in^4	198.99 in^4
Section Modulus:	49.91 in^3	33.86 in^3
Section Area:	32.38 in^2	19.4 in^2
Bearing Area:		5.65 in^2
Minimum bearing dimensions:	3.5 in x	1.61 in

John S. Apolis, P.E. CSES, Inc.

Job number: 2022.136

Project: Li Residence

Date: 13-Oct-22

Designer: Shawn Sullivan

Page number: U32

**BEAM DESIGN (Uniform Load+Concentrated Load)**

2018 International Building Code (IBC)

2018 NDS

**Beam Description: Grid C Header 3**

Fully Supported:	1	Snow Load:	1	Wind Load:	
Repetitive Member:		P.T. Lumber:		Wet Use:	

**Geometry and Loads:**

Span:	15 ft	Tributary Width:	8 ft	P Location:	3.75 ft
Add'l uniform DL:	120 lbs/ft	DL unit load:	12 psf	Concentrated DL:	
Add'l uniform LL:		LL unit load:	60 psf	Concentrated LL:	
Add'l uniform SL:	200 lbs/ft	SL unit load:	25 psf	Concentrated SL:	
Add'l uniform WL:		WL unit load:		Concentrated WL:	

DL Reaction 1:	1620 lbs	DL Reaction 2:	1620 lbs	Note: Design automatically uses ASD load combinations
LL Reaction 1:	3600 lbs	LL Reaction 2:	3600 lbs	
SL Reaction 1:	3000 lbs	SL Reaction 2:	3000 lbs	
WL Reaction 1:	0 lbs	WL Reaction 2:	0 lbs	
Total Reaction 1:	<b>6570 lbs</b>	Total Reaction 2:	<b>6570 lbs</b>	

**Material Properties:**

E	2.2 msi	E'	2.2 msi
Fb	2900 psi	Fb'	3230 psi
Fv	290 psi	Fv'	334 psi
Fc perp	625 psi	Fc perp'	625 psi
Emin	0.914 msi	Emin'	0.914 msi

**Deflection analysis:**

For total load: Allowed deflection criteria, span/	240		
For LL only: Allowed deflection criteria, span/	360		
Max. allowed total defl:	0.75 in	Max LL defl:	0.5 in
Total defl. * I:	567.46 in^4	Required I:	756.61 in^4
LL defl. * I:	455.63 in^4	Required I:	911.25 in^4
Actual deflections: TOTAL:	0.47 in		0.38 in

**Force analysis:**

Max. moment:	24638 ft-lb	Max Shear:	6570 lbs
--------------	-------------	------------	----------

**Selected Member: (1) PSL 3.5 x 16**

<b>Member properties:</b>	<b>Provided:</b>	<b>Required:</b>
Moment of inertia:	1194.67 in^4	911.25 in^4
Section Modulus:	149.33 in^3	91.53 in^3
Section Area:	56. in^2	29.55 in^2
Bearing Area:		10.51 in^2
Minimum bearing dimensions:	3.5 in x	3. in

John S. Apolis, P.E.

CSES, Inc.

Job number: 2022.136

Project: Li Residence

Date: 13-Oct-22

Designer: Shawn Sullivan

Page number: U33

**Post Design (Combined Axial and Moment Loading)**

2018 International Building Code (IBC)

2018 NDS

**Post Description: Beam U32 Support**

Snow Load:	1	Wind Load:	
Repetitive Member:		P.T. Lumber:	

**Geometry and loads:**

Height	9 ft	w(d)	0 plf	M(d)	
Axial Load	6570 lbs	w(b)	0 plf	M(b)	0 ft-lbs
Le(d)	9 ft	Le(b)	9 ft		

**Material Properties:**

Fb1	900 psi	Fb(d)'	1035 psi
Fb2	900 psi	Fb(b)'	1035 psi
Fc	1350 psi	Fc'	461.64 psi
E	1.6 msi	E'	1.6 msi
Emin	0.58 msi	Emin'	0.58 msi

**Selected Member:** DF #2 3.5 x 5.5

**Member properties:**

Section Modulus (d):	17.6 in^3
Section Modulus (b):	11.2 in^3
Section Area:	19.3 in^2

**Variables:**

Rb(d)	3.53
Rb(b)	6.96
c	0.8

**Member stresses: Provided**

FcE(d)	1236 psi	>
FcE(b)	501 psi	>
FbE	14354 psi	>
FbE	14354 psi	>

**Required**

fc	341 psi	OK
fc	341 psi	OK
fb(d)	0 psi	OK
fb(b)	0 psi	OK

**Bending and Axial Compression Check:**

NDS 2018 EQ 3.9-3 0.55 < 1.0 **OK**



John S. Apolis, P.E. CSES, Inc.

Job number: 2022.136

Project: Li Residence

Date: 13-Oct-22

Designer: Shawn Sullivan

Page number: U34

**BEAM DESIGN (Uniform Load+Concentrated Load)**

2018 International Building Code (IBC)

2018 NDS

**Beam Description: South East Garage Header**

Fully Supported:	1	Snow Load:	1	Wind Load:	
Repetitive Member:		P.T. Lumber:		Wet Use:	

**Geometry and Loads:**

Span:	18 ft	Tributary Width:	2 ft	P Location:	3.75 ft
Add'l uniform DL:	80 lbs/ft	DL unit load:	15 psf	Concentrated DL:	
Add'l uniform LL:		LL unit load:	60 psf	Concentrated LL:	
Add'l uniform SL:		SL unit load:	25 psf	Concentrated SL:	
Add'l uniform WL:		WL unit load:		Concentrated WL:	

DL Reaction 1:	990 lbs	DL Reaction 2:	990 lbs	Note: Design automatically uses
LL Reaction 1:	1080 lbs	LL Reaction 2:	1080 lbs	ASD load combinations
SL Reaction 1:	450 lbs	SL Reaction 2:	450 lbs	1
WL Reaction 1:	0 lbs	WL Reaction 2:	0 lbs	
Total Reaction 1:	<b>2138 lbs</b>	Total Reaction 2:	<b>2138 lbs</b>	

**Material Properties:**

E	2 msi	E'	2 msi
Fb	2600 psi	Fb'	2994 psi
Fv	285 psi	Fv'	328 psi
Fc perp	750 psi	Fc perp'	750 psi
Emin	1.016 msi	Emin'	1.016 msi

**Deflection analysis:**

For total load: Allowed deflection criteria, span/	240		
For LL only: Allowed deflection criteria, span/	360		
Max. allowed total defl:	0.9 in	Max LL defl:	0.6 in
Total defl. * I:	330.67 in^4	Required I:	367.42 in^4
LL defl. * I:	200.77 in^4	Required I:	334.61 in^4
Actual deflections:	TOTAL: 0.68 in		0.41 in

**Force analysis:**

Max. moment:	9619 ft-lb	Max Shear:	2138 lbs
--------------	------------	------------	----------

**Selected Member: (2) LVL 1.75 x 11.875**

<b>Member properties:</b>	<b>Provided:</b>	<b>Required:</b>
Moment of inertia:	488.41 in^4	367.42 in^4
Section Modulus:	82.26 in^3	38.55 in^3
Section Area:	41.56 in^2	9.78 in^2
Bearing Area:		2.85 in^2
Minimum bearing dimensions:	3.5 in x	0.81 in

John S. Apolis, P.E. CSES, Inc.

Job number: 2022.136

Project: Li Residence

Date: 13-Oct-22

Designer: Shawn Sullivan

Page number: U35

**BEAM DESIGN (Uniform Load+Concentrated Load)**

2018 International Building Code (IBC)

2018 NDS

**Beam Description: Stair Opening East Flush Beam**

Fully Supported:	1	Snow Load:		Wind Load:	
Repetitive Member:		P.T. Lumber:		Wet Use:	

**Geometry and Loads:**

Span:	7 ft	Tributary Width:	8.5 ft	P Location:	3.25 ft
Add'l uniform DL:	48 lbs/ft	DL unit load:	12 psf	Concentrated DL:	202.5 lbs
Add'l uniform LL:	240 lbs/ft	LL unit load:	40 psf	Concentrated LL:	1012.5 lbs
Add'l uniform SL:		SL unit load:		Concentrated SL:	
Add'l uniform WL:		WL unit load:		Concentrated WL:	

DL Reaction 1:	633 lbs	DL Reaction 2:	619 lbs	Note: Design automatically uses
LL Reaction 1:	2572 lbs	LL Reaction 2:	2500 lbs	ASD load combinations
SL Reaction 1:	0 lbs	SL Reaction 2:	0 lbs	1
WL Reaction 1:	0 lbs	WL Reaction 2:	0 lbs	
Total Reaction 1:	<b>3206 lbs</b>	Total Reaction 2:	<b>3119 lbs</b>	

**Material Properties:**

E	2 msi	E'	2 msi
Fb	2600 psi	Fb'	2500 psi
Fv	285 psi	Fv'	285 psi
Fc perp	750 psi	Fc perp'	750 psi
Emin	1.016 msi	Emin'	1.016 msi

**Deflection analysis:**

For total load: Allowed deflection criteria, span/	240		
For LL only: Allowed deflection criteria, span/	360		
Max. allowed total defl:	0.35 in	Max LL defl:	0.23 in
Total defl. * I:	27.17 in^4	Required I:	77.63 in^4
LL defl. * I:	21.88 in^4	Required I:	93.75 in^4
Actual deflections:	TOTAL: 0.02 in		0.02 in

**Force analysis:**

Max. moment:	6564 ft-lb	Max Shear:	3206 lbs
--------------	------------	------------	----------

**Selected Member: (2) LVL 1.75 x 16**

<b>Member properties:</b>	<b>Provided:</b>	<b>Required:</b>
Moment of inertia:	1194.67 in^4	93.75 in^4
Section Modulus:	149.33 in^3	31.5 in^3
Section Area:	56. in^2	16.87 in^2
Bearing Area:		4.27 in^2
Minimum bearing dimensions:	3.5 in x	1.22 in

John S. Apolis, P.E.

CSES, Inc.

Job number: 2022.136

Project: Li Residence

Date: 13-Oct-22

Architect: Shawn Sullivan

Page number: U36

**Steel Post Design**

2018 International Building Code (IBC)

**Design Information:**

Gravity Load:	3360 lbs	Moment:	0 ft-lbs
Height:	12 ft	K:	1.2
E	29000 ksi	Fy:	46 ksi

**Gravity Load Design**

Kl/r	155.68	$4.71 \cdot \sqrt{E/F_y}$	118.26	
Fe	11,810 psi	Fcr	10,358 psi	
Pc	15,133 lbs	>	3360	lbs

**Lateral Load Design**

(Compact sections only)

F7-1 Mn	114080			
Mc	114080 in-lbs	>	0	in-lbs

**Combined Axial/Flexural Load Design**

Pr/Pc	0.22	>	0.2 H1-1a
H1-1a	0.22	<	1 OK

Column Specification:

HSS3x3x1/4

Z: 2.48

A: 2.44  
S: 2.01  
I: 3.02  
r: 1.11

# 2022.136 Li Residence

4657 86th Ave SE, Mercer Island, WA 98040, USA

Latitude, Longitude: 47.5621293, -122.2245528

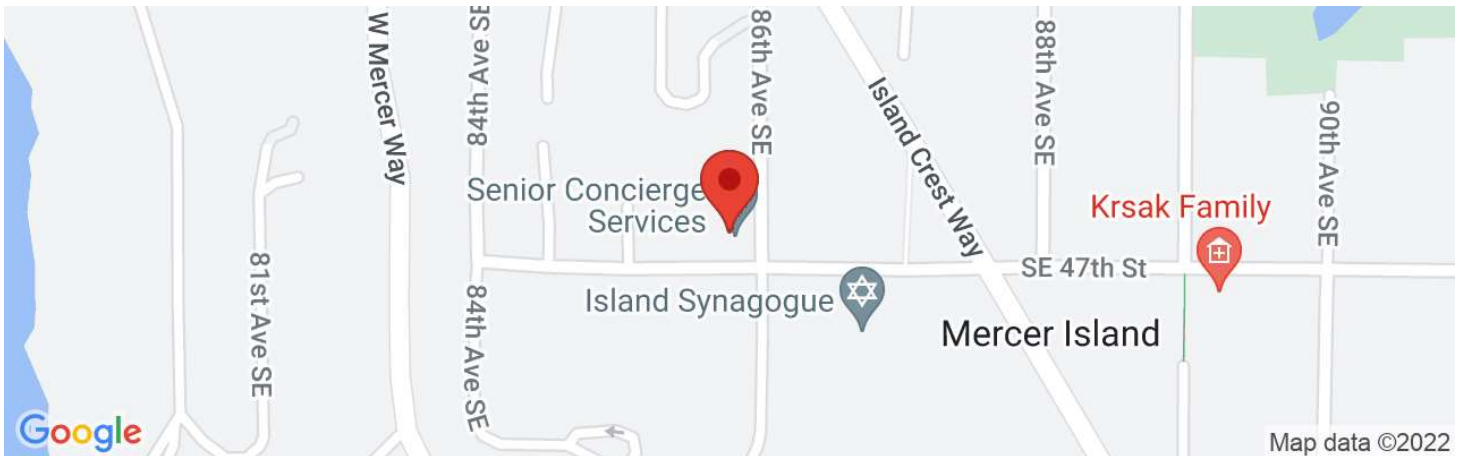

<b>Date</b>	9/6/2022, 2:33:19 AM
<b>Design Code Reference Document</b>	ASCE7-16
<b>Risk Category</b>	II
<b>Site Class</b>	D - Default (See Section 11.4.3)

Type	Value	Description
$S_S$	1.436	$MCE_R$ ground motion. (for 0.2 second period)
$S_1$	0.499	$MCE_R$ ground motion. (for 1.0s period)
$S_{MS}$	1.723	Site-modified spectral acceleration value
$S_{M1}$	null -See Section 11.4.8	Site-modified spectral acceleration value
$S_{DS}$	1.149	Numeric seismic design value at 0.2 second SA
$S_{D1}$	null -See Section 11.4.8	Numeric seismic design value at 1.0 second SA

**Lateral Loads Design per ASCE 7-16, Wind: Section 28 Seismic: Section 12**

**(Simplified Envelope Procedure Part 2)**

2015 & 2018 International Building Code (IBC)

**WIND LOADS** 110 mph Basic Wind Speed 2018 NDS

$P_s = \lambda * K_{zt} * P_s(30) * 0.6$  Exposure B Roof Slope: 0.00 : 12 = 0.0

Least Horizontal Dimension, feet: 64 Mean Roof Ht, feet: 25 (degrees)

$\lambda = 1.00$  a = 6.4 ft, 2a = 12.8 ft

$I_w = 1.00$   $K_{zT} = 1.60$

<u>Tabulated Ps(30):</u>	<u>Zone</u>	<u>Tabulated Wind Pressure</u>	<u>Calc'd Design Pressure</u>	<u>Min Design Pressure</u>	(Per section 28.6.4 minimum tabulated wind pressure is 16 PSF for zones A, C, and 8 PSF for zones B, D)
(Refer to ASCE 7-16, Figure 28.6-1)			(* $\lambda * K_{zT} * 0.6$ )		
(horizontal)	A	19.2	psf 18.4	18.4	
"	B	-10.0	psf -9.6	9.6	
"	C	12.7	psf 12.2	15.4	
"	D	-5.9	psf -5.7	7.7	
(vertical)	E	-23.1	psf -22.2		
"	F	-13.1	psf -12.6		
"	G	-16.0	psf -15.4		
"	H	-10.1	psf -9.7		
(uplift on overhangs)	E(oh)	-32.3	psf -31.0		
"	G(oh)	-25.3	psf -24.3		

**(Equivalent Lateral Force Procedure, Section 12.8)**

<u>SEISMIC LOADS</u>	Ie	R =	ASCE 7-16, Table 12.2.1
Seismic Parameters	Group I	Site Class: D	
per ASCE 7-16)	PGA (.2 sec)	1.4360	Fa = 1.00 ASCE 7-16 Table 11.4-1
	PGA (1 sec)	0.4990	Fv = 1.60 ASCE 7-16 Table 11.4-2

**Seismic Design Categories per ASCE 7-16 Tables 11.6-1, 11.6-2**

Based on Sds: D Based on Sd1: D

PGA's based on peak ground accelerations per latest USGS Hazards Program (based on lat/lon).

$S_s = 1.4360$   $S_{ms} = F_a * S_s = 1.44$  Equation 11.4-1

$S_1 = 0.4990$   $S_{m1} = F_v * S_1 = 0.80$  Equation 11.4-2

Equations 11.4-3, 11.4-4  $S_{ds} = 2/3 * S_{ms} = 0.96$   $S_{d1} = 2/3 * S_{m1} = 0.53$

Equation 12.14-11  $C_s (\%V) = (S_{ds} / (R/I)) = 0.147$  **Building period < 0.5 s per IBC eq 12.8-7**

**Base Shear = %V \* W \* 0.7 = 4.64 psf**, uniformly distributed over floor area  
 (0.7 reduction factor per ASCE 7-16, Section 2.4.1, Eq (seismic vertical distribution per IBC eqs 12.8-11 & 12)

	<u>Roof DL</u>	<u>Wall DL (psf)</u>	<u>Story Height</u>	<u>Lateral</u>
Base = top of foundation	<u>(psf)</u>	<u>dist. over floor area</u>	<u>Above Base (ft)</u>	<u>Load (psf)</u>
Roof	15	6	21	2.90
Main Floor	12	12	11	1.74
<b>Total Seismic DL:</b>	<b>45</b>		Sum	<b>4.64</b>

## LATERAL DESIGN - ROOF LEVEL

NORTH SHEAR WALL - L = 27'

$$P_w = 12.0' \times 6' \times 18.4 \text{ psf} + 6.5' \times 6' \times 15.4 \text{ psf} = 2,014 \# //$$

$$P_E = 19.25' \times 30' \times 2.90 \text{ psf} = 1,675 \#$$

$$V = \frac{2,014 \#}{27'} = 75 \text{ plf} < 100 \text{ plf} \Rightarrow \text{SW } \emptyset$$

$$H = 75 \text{ plf} \times 12' = 900 \# < 1,705 \# \Rightarrow \text{CS16}$$
$$< 2,215 \# \Rightarrow \text{HD02}$$

E-W INTERIOR SHEAR WALL - L = 17'

$$P_w = (12' + 19.25') \times 5.5' \times 15.4 \text{ psf} = 2,647 \#$$

$$P_E = [(12' + 16') \times 42' + 3.25' \times 30'] \times 2.90 \text{ psf} = 3,693 \# //$$

$$V = \frac{3,693 \#}{17'} = 217 \text{ plf} < 230 \text{ plf} \Rightarrow \text{SW } 1$$

$$H = 217 \text{ plf} \times 10' = 2,170 \# < (2) 1,705 \# \Rightarrow (2) \text{ CS16}$$

SOUTH SHEAR WALL - L = 11'

$$P_w = 12' \times 6' \times 18.4 \text{ psf} = 1,325 \#$$

$$P_E = 12' \times 42' \times 2.90 \text{ psf} = 1,462 \# //$$

$$V = \frac{1,462 \#}{11'} = 133 \text{ plf} < 230 \text{ plf} \Rightarrow \text{SW } 1$$

$$H = 133 \text{ plf} \times 12' = 1,596 \# < 3,900 \# \Rightarrow \text{MST248B3}$$

### CONSULTING STRUCTURAL ENGINEERING SERVICES

Residential and Commercial Structural Design

6311 17th Avenue NE, Seattle, WA 98115

Phone: (206)527-1288 Email: john@cses-engineering.com

Project No. 2022.136 Date 9-7-22

Project Name LI RESIDENCE

Comments \_\_\_\_\_

Revision \_\_\_\_\_ Page L2

# LATERAL DESIGN - ROOF LEVEL

## NORTH-SOUTH LOADING DIAPHRAGM ANALYSIS:

WIND:

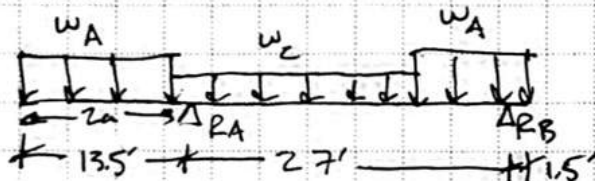

$$w_A = 6' \times 18.4 \text{ psf} = 110 \text{ plf}$$

$$w_C = 6' \times 15.4 \text{ psf} = 92 \text{ plf}$$

$$2a = 12.8'$$

$$\sum M, \sum F \Rightarrow R_{t,w} = 3,120 \#$$

$$R_{B,w} = 1,200 \#$$

EARTHQUAKE:



$$w_1 = 38' \times 2.90 \text{ psf} = 110 \text{ plf}$$

$$w_2 = 60' \times 2.90 \text{ psf} = 174 \text{ plf}$$

$$R_{A,eq} = 4,200 \# \quad R_{B,eq} = 2,250 \#$$

EAST SHEAR WALL -  $L = 13.5'$

$$P_w = 1,200 \# \quad P_E = 2,250 \#$$

$$v = \frac{2,250 \#}{13.5'} = 167 \text{ plf} < 230 \text{ plf} \Rightarrow \text{SW 1}$$

$$H = 167 \text{ plf} \times 12' = 2,004 \# < (2) 1,705 \# \Rightarrow (2) \text{CS16}$$

WEST SHEAR WALL -  $L = 9' + 8'$

$$P_w = 3,120 \# \quad P_E = 4,200 \#$$

$$v = \frac{4,200 \#}{17'} = 247 \text{ plf} < 350 \text{ plf} \Rightarrow \text{SW 2}$$

$$H = 247 \text{ plf} \times 12' = 2,964 \# < (2) 1,705 \# \Rightarrow (2) \text{CS16}$$

### CONSULTING STRUCTURAL ENGINEERING SERVICES

Residential and Commercial Structural Design

6311 17th Avenue NE, Seattle, WA 98115

Phone: (206)527-1288 Email: john@cses-engineering.com

Project No. 2022.136 Date 9-7-22

Project Name LI RESIDENCE

Comments \_\_\_\_\_

Revision \_\_\_\_\_ Page L3



# LATERAL DESIGN - UPPER FLOOR LEVEL

NORTH SHEAR WALL, EAST DIAPHRAGM -  $L = 27'$

$$P_w = 2,014\# + 12.8' \times 11' \times 18.4 \text{ psf} + 8.5' \times 11' \times 15.4 \text{ psf} = 6,045\#$$

$$P_E = 1,675\# + 20.5' \times 30' \times 1.74 \text{ psf} = 2,745\#$$

$$V = \frac{6,045\#}{27'} = 224 \text{ plf} < 230 \text{ plf} \Rightarrow \underline{\text{SW1}}$$

$$H = 224 \text{ plf} \times 5' = 1,220\# < 2,215\# \Rightarrow \underline{\text{HDU2}}$$

SOUTH EAST DIAPHRAGM, EAST-WEST LOADING

WIND:

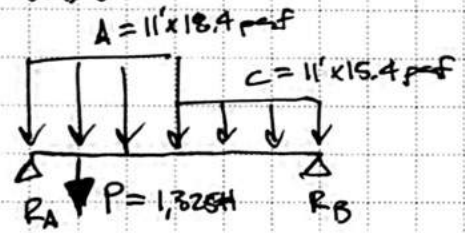

$$R_{A,w} = 3,440\#$$

$$R_{B,w} = 2,360\#$$

EARTHQUAKE:

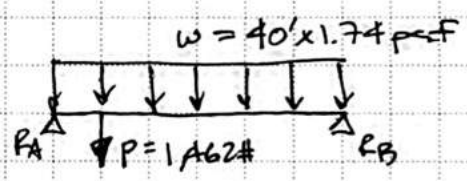

$$R_{A,eq} = 2,060\#$$

$$R_{B,eq} = 1,080\#$$

EAST-WEST INTERIOR SHEAR WALL -  $L = 17'$

$$P_w = 2,647\# + 2,360\# + 20' \times 11' \times 15.4 \text{ psf} = 8,395\#$$

$$P_E = 3,693\# + 20' \times 30' \times 1.74 \text{ psf} = 4,737\#$$

$$V = \frac{8,395\#}{17'} = 494 \text{ plf} < 550 \text{ plf} \Rightarrow \underline{\text{SW3}}$$

$$H = 2,176\# + 494 \text{ plf} \times 10' = 7,110\# < 7,870\# \Rightarrow \underline{\text{HDU8 w/4x6 DF}}$$

## CONSULTING STRUCTURAL ENGINEERING SERVICES

Residential and Commercial Structural Design

6311 17th Avenue NE, Seattle, WA 98115

Phone: (206)527-1288 Email: john@cses-engineering.com

Project No. 2022.136 Date 9-7-22

Project Name LI RESIDENCE

Comments \_\_\_\_\_

Revision \_\_\_\_\_ Page LA



## LATERAL DESIGN - UPPER FLOOR LEVEL

SOUTH SHEAR WALL -  $L = 10.5'$

$$P_w = 3,440\#$$

$$P_E = 2,060\# + 16' \times 20' \times 1.74 \text{ psf} = 2,617\#$$

$$v = \frac{3,440\#}{10.5'} = 328 \text{ plf} < 350 \text{ plf} \Rightarrow \underline{\text{SW2}}$$

$$H = 328 \text{ plf} \times 10' = 3,280\# < 4,340\# \Rightarrow \underline{\text{HDU5}}$$

NORTH SHEAR WALL, WEST DIAPHRAGM -  $L = 16'$

$$P_w = 12.8' \times 6' \times 18.4 \text{ psf} + 7.2' \times 6' \times 15.4 \text{ psf} = 2,078\#$$

$$P_E = 20' \times 36' \times 1.74 \text{ psf} = 1,253\#$$

$$v = \frac{2,078\#}{16'} = 130 \text{ plf} < 230 \text{ plf} \Rightarrow \underline{\text{SW1}}$$

$$H = 130 \text{ plf} \times 12' = 1,560\# < 2,215\# \Rightarrow \underline{\text{HDU2}}$$

EAST SHEAR WALL -  $L = 19'$

$$P_w = 1,200\# + 12.8' \times 11' \times 18.4 \text{ psf} + 2.2' \times 11' \times 15.4 \text{ psf} = 4,163\#$$

$$P_E = 2,250\# + 15' \times 64' \times 1.74 \text{ psf} = 3,920\#$$

$$v = \frac{4,163\#}{19'} = 219 \text{ plf} < 230 \text{ plf} \Rightarrow \underline{\text{SW1}}$$

$$H = 219 \text{ plf} \times 10' = 2,190\# < 2,215\# \Rightarrow \underline{\text{HDU2}}$$

$$+ 2,004\#$$

$$4,194\# < 4,340\# \Rightarrow \underline{\text{HDU5}}$$

### CONSULTING STRUCTURAL ENGINEERING SERVICES

Residential and Commercial Structural Design

6311 17th Avenue NE, Seattle, WA 98115

Phone: (206)527-1288 Email: john@cses-engineering.com

Project No. 2022.136 Date 9-7-22

Project Name LI RESIDENCE

Comments \_\_\_\_\_

Revision \_\_\_\_\_ Page L5

# LATERAL DESIGN - UPPER FLOOR LEVEL

SOUTH SHEAR WALL, DINING ROOM -  $L = 13'$

$$P_w = 12.8' \times 6' \times 18.4 \text{ psf} + 7.2' \times 6' \times 15.4 \text{ psf} = 2,078 \#$$

$$P_E = 20' \times 16' \times 1.74 \text{ psf} = 557 \#$$

$$v = \frac{2,078 \#}{13'} = 160 \text{ plf} < 230 \text{ plf} \Rightarrow \underline{\text{SW1}}$$

$$H = 160 \text{ plf} \times 12' = 1,920 \# < 2,215 \# \Rightarrow \underline{\text{HD02}}$$

WEST DIAPHRAGM, NORTH-SOUTH LOADING

WIND:

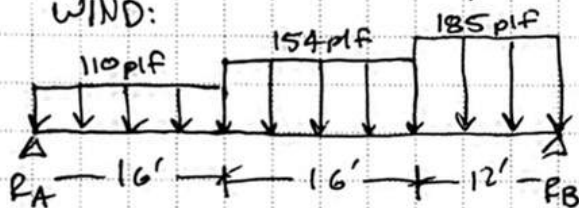

$$R_{A,W} = 2,860 \#$$

$$R_{B,W} = 3,580 \#$$

$$V_{e16'} = 1,100 \#, L = 40' \Rightarrow v = 28 \text{ plf} \Rightarrow \underline{\text{SW0}}$$

$$V_{e32'} = 1,360 \#, L = 40' \Rightarrow v = 34 \text{ plf} \Rightarrow \underline{\text{SW0}}$$

EARTH QUAKE:

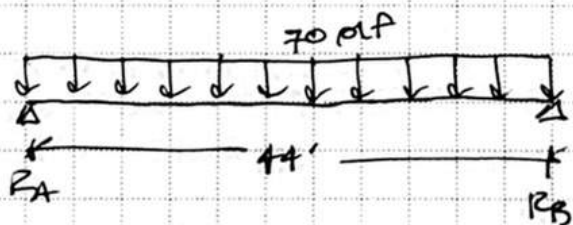

$$R_{A,EQ} = R_{B,EQ} = 1,540 \#$$

$$V_{e16'} = 155 \#$$

$$V_{e32'} = 71 \#$$

**CONSULTING STRUCTURAL ENGINEERING SERVICES**

Residential and Commercial Structural Design

6311 17th Avenue NE, Seattle, WA 98115

Phone: (206)527-1288 Email: john@cses-engineering.com

Project No. 2022.136 Date 9-8-22

Project Name LI RESIDENCE

Comments \_\_\_\_\_

Revision \_\_\_\_\_ Page L6

## LATERAL DESIGN - UPPER FLOOR LEVEL

WEST SHEAR WALL -  $L = 7'$

$$P_w = 2,860\#, \quad P_e = 1,540\# \quad (L6)$$

$$v = \frac{2,860\#}{7'} = 409 \text{ plf} < 550 \text{ plf} \Rightarrow \underline{\text{SW3}}$$

$$H = 409 \text{ plf} \times 12' = 4,908\# < 5,645\# \Rightarrow \underline{\text{HDUS w/ DF Post}}$$

N-S INTERIOR SHEAR WALL -  $L = 14'$

$$P_w = 3,120\# + 3,580\# + 15' \times 11' \times 15.4 \text{ psf} = 9,241\# //$$

(L3)      (L6)

$$P_e = 4,200\# + 1,540\# + 64' \times 15' \times 1.74 \text{ psf} = 7,410\#$$

(L3)      (L6)

$$v = \frac{9,241\#}{14'} = 660 \text{ plf} < 710 \text{ plf} \Rightarrow \underline{\text{SW3X}}$$

$$H = 660 \text{ plf} \times 10' = 6,600\# < 6,970\# \Rightarrow \underline{\text{HDUS w/ 4x4 DF}}$$

### CONSULTING STRUCTURAL ENGINEERING SERVICES

Residential and Commercial Structural Design

6311 17th Avenue NE, Seattle, WA 98115

Phone: (206)527-1288 Email: john@cses-engineering.com

Project No. 2022.136 Date 9-8-22

Project Name LI RESIDENCE

Comments \_\_\_\_\_

Revision \_\_\_\_\_ Page L7